

**TYPLOGIES**

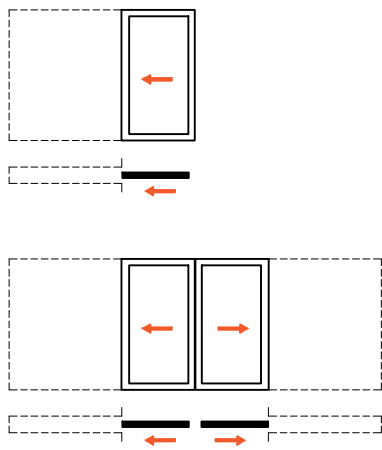

**CEILING FUNCTION TYPLOGIES**

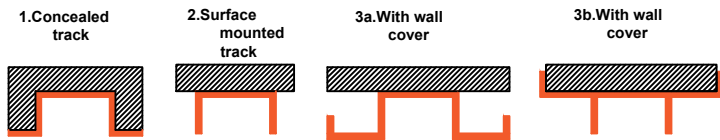

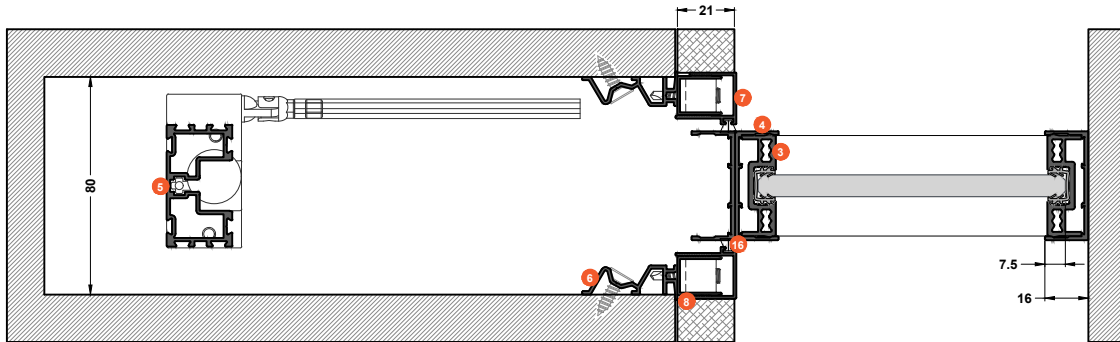
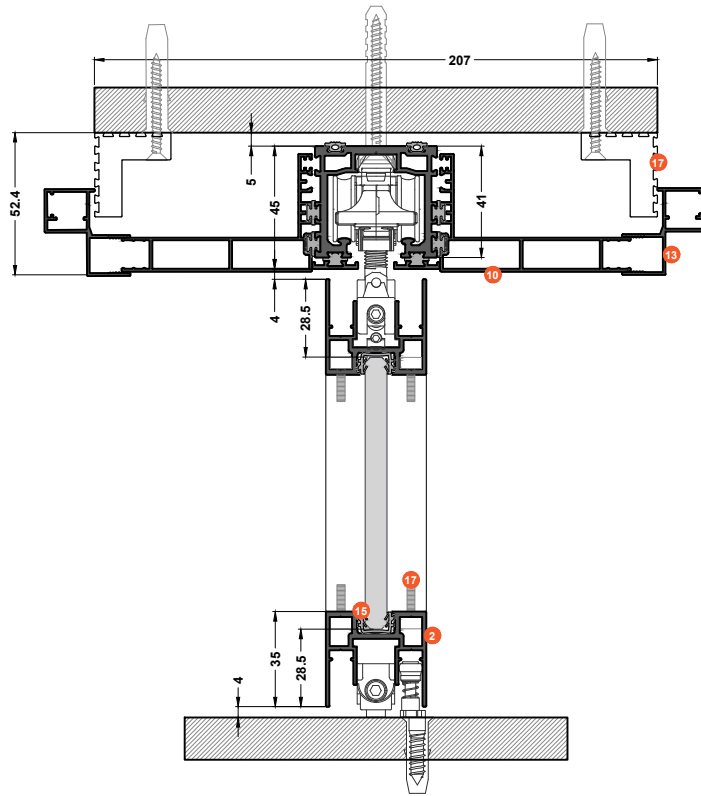



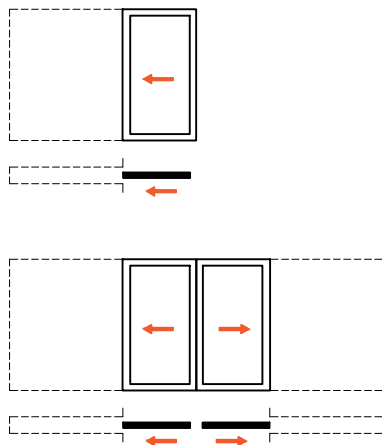



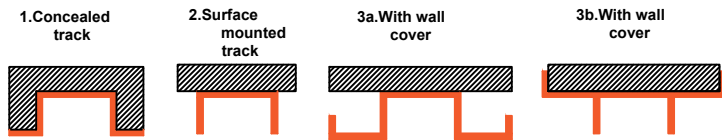



















**TYPOLOGIES**



**CEILING FUNCTION TYPOLOGIES**

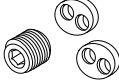

- 1  GT80-1 - 1350 gr/m | Guide track
- 2  GT20-1 - 760 gr/m | Door frame
- 3  GT20-2 - 450 gr/m | Door frame
- 4  GT20-3 - 270 gr/m | Door frame cover
- 5  GT82 - 680 gr/m | Support rod
- 6  GT84-1 - 240 gr/m | Fixing support profile
- 7  GT84-3 - 240 gr/m | U shape adjust profile
- 8  GT84-2 - 130 gr/m | U shape adjust profile
- 9  GT82-1 - 80 gr/m | Track cover
- 10  GT83-5 - 650 gr/m | Track cover
- 11  GT83-3 - 450 gr/m | Wall frame
- 12  GT83-2 - 950 gr/m | Wall frame
- 13  GT29-1 - 320 gr/m | Track cover
- 14  PH05 | Handle
- 15  GGO-01-KIT | Corner
- 16  GGO-02-KIT | Corner

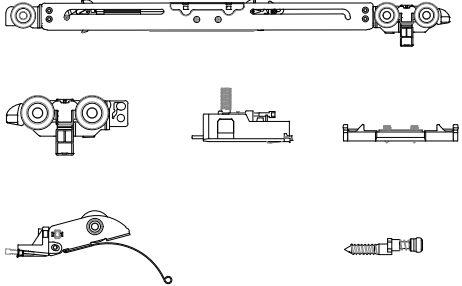
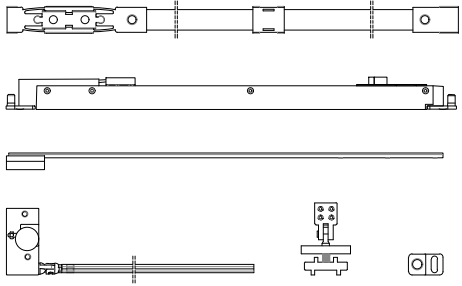
- 17  PB01 | Plastic bar for full cover
- 18  GT20-C2-KIT | Connector gasket
- 19  GT20-C1-KIT | Connector gasket
- 20  GT20-R | Rubber
- 21  S39 | Rubber
- 22  BRUSH 4.4 | Brush
- 23  SCREW-01-KIT | Screw for level and rubber pad
- 24  TZ-01-KIT | Fix connector
- 25  GT20-SC-KIT | Screw
- 26  GT80-SP1-KIT | Track positioning part
- 27  GT80S-KIT
- 28  GT80P-KIT

1  GT80-1 - 1350 gr/m | Guide track

2  GT20-1 - 760 gr/m | Door frame

3  GT20-2 - 450 gr/m | Door frame

4  GT20-3 - 270 gr/m | Door frame cover

5  GT82 - 680 gr/m | Support rod

6  GT84-1 - 240 gr/m | Fixing support profile

7  GT84-4 - 180 gr/m | U shape adjust profile

8  GT84-2 - 130 gr/m | U shape adjust profile

9  GT82-1 - 80 gr/m | Track cover

10  GT82-6 - 250 gr/m | Cover

11  PH05 | Handle

12  GT20-C2-KIT | Connector gasket

13  GT20-C1-KIT | Connector gasket

14  GT20-R | Rubber

15  S39 | Rubber

16  BRUSH 4.4 | Brush

17  GT20-SC-KIT | Screw

18  SCREW-01-KIT | Screw for level and rubber pad

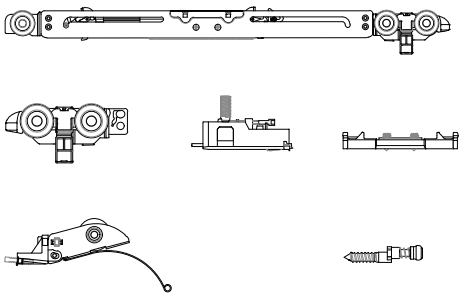
19  GT80S-KIT

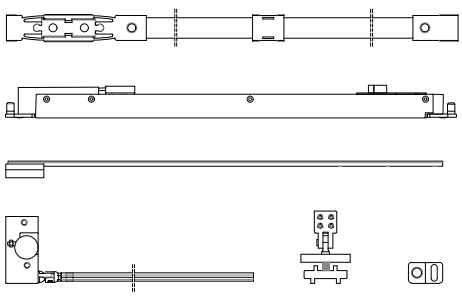
20  GT80P-KIT