

community



Distributor pro ČR a SK
www.mintiga.cz
obchod@mintiga.cz
+420 724 124 042

Diemme.

kire



Distributor pro ČR a SK
www.mintiga.cz
obchod@mintiga.cz
+420 724 124 042

Diemme.

kire

furniture to
connect people

Kire

Introduzione | Introduction | Introduction

5

Sedia ibrida per ospitalità e spazio di lavoro

Hospitality and workspace hybrid chair | Hospitalité et espace de travail chaise hybride

8

Comfort e sostenibilità

Comfort and sustainability | Confort et durabilité

16

Moderna versatilità

Modern versatility | Polyvalence moderne

22

Rivestimenti

Upholstery | Nuanciers

35

Reinterpretazione della sedia multifunzionale monoscocca, la collezione **KIRE**, disegnata da Giorgio Topan, prende ispirazione a partire dal significato del suo nome: "taglio". Leggera, essenziale, con richiami al design scandinavo, è facilmente riconoscibile grazie alla sua silhouette laterale. La libertà di movimento offerta dalla sua forma e le infinite possibilità di combinazione, ne fanno una versatile famiglia di sedute dall'aspetto lineare e contemporaneo, adatte a qualunque ambiente: ufficio, casa e spazi pubblici.

KIRE
Giorgio Topan / 2022

05

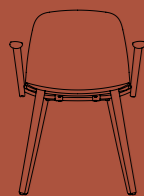

The KIRE collection, designed by Giorgio Topan, revisits the multi-purpose single-shell chair, taking initial inspiration from the meaning of its name: "cut." Light and unfussy, with shades of Scandinavian design, KIRE's profile is instantly recognisable. Its shape assures freedom of movement and combines with endless combinations of chair features to make KIRE a versatile seating collection with a linear and contemporary look, suitable for any setting: office, home and public spaces.

Réinterprétation de la chaise monocoque multifonctionnelle, la Collection KIRE, conçue par Giorgio Topan, prend son inspiration à partir de la signification de son nom: "couper". Légère, incontournable, avec des références au design scandinave, il est facilement reconnaissable grâce à sa silhouette latérale. La liberté de mouvement offerte par sa forme et les possibilités infinies de combinaisons, en font une famille polyvalente de sièges avec un look linéaire et contemporain, adaptée à tout environnement: bureau, maison et espaces publics.



Hospitality and workspace, hybrid chair.

Una forma semplice ed informale, ma che racchiude infinite possibilità di personalizzazione, per essere discreta o protagonista dello spazio in cui viene inserita.

Kire è una collezione di sedie, sgabelli e panche, progettata all'insegna della versatilità e delle nuove esigenze di mercato, come ad esempio il settore hospitality, che si sta integrando sempre più con il mondo workspace, sulla scia della nuova tendenza di mixare casa e ufficio.

Un sistema composto da una seduta monoscocca in 6 colorazioni, diversi telai e una vasta gamma di tessuti, danno vita ad innumerevoli soluzioni, variando tonalità e texture per ottenere ambienti e funzioni di volta in volta diversi.

Gli accessori di Kire, come ad esempio la tavoletta e i braccioli, abbinati alla monoscocca anche totalmente o parzialmente rivestita, contribuiscono a renderla estremamente trasversale, dal contract al residenziale, dalle sale conferenza agli spazi hospitality, dagli ambienti lavorativi all'intimità di casa.

A simple, informal and infinitely customisable design, which allows it either to blend in to stand out in any setting. Kire is a collection of chairs, stools and benches, designed with versatility and the latest market requirements in mind: for instance the hospitality sector, which is increasingly integrating with the world of workspaces, in the wake of the new trend of combining home and office. A system consisting of a single shell in a choice of 6 colours, various bases, and a wide range of fabrics, all bringing to life countless solutions, varying shades and textures resulting in different environments and functions each time. Accessories such as the writing tablet, armrests, and whole or partial upholstery of the shell make Kire extremely eclectic in terms of application: from contract to residential, from conference rooms to hospitality spaces, from workplaces to the cosiness of home.

Une forme simple et informelle, mais qui contient une infinie de possibilités de personnalisation, pour être discrète ou protagoniste de l'espace dans lequel elle s'insère. Kire est une collection de chaises, tabourets et bancs, conçue au nom de la polyvalence et des nouveaux besoins du marché, comme par exemple le secteur de l'hospitalité, qui intègre de plus en plus le monde de l'espace de travail, dans le sillage de la nouvelle tendance à mélanger maison et bureau. Un système composé d'un siège monocoque de 6 couleurs, différents châssis et une large gamme de tissus, ils donnent vie à d'innombrables solutions, nuances et textures variées pour obtenir environnements et fonctions de temps en temps différents. Les accessoires de Kire, tels que la tablette et les accoudoirs, combinés avec la monocoque également totalement ou partiellement rembourrée, contribuent à le rendre extrêmement transversal, du contract au résidentiel, des salles de conférence aux espaces d'hospitalité, des environnements de travail à l'intimité de la maison.

KIRE





KIRE



Kire visitor chair / Mattone - One 4566



Kire visitor chair / Bianco - Mirage 234

KIRE



Kire visitor chair / Wolin 7050.36



Kire visitor stool / Ocra - Jet 9110 / Ocra

Comfort e sostenibilità

L'innovazione vera e propria permette di soddisfare le esigenze sia attuali che future. Per questa ragione l'Azienda Diemme pone l'accento sulla durata dei prodotti e nei materiali impiegati per realizzarli.

Grazie alle nostre politiche di approvvigionamento e al rispetto dei programmi di certificazione, garantiamo che i materiali acquistati soddisfino le condizioni che l'azienda si è preposta di seguire in materia di diritti umani e standard ambientali. Creatività ed esperienza si fondono assieme, nella messa a punto di progetti innovativi per la totale soddisfazione del cliente e per l'ecosostenibilità vincolata alla facilità di smaltimento.

È responsabilità del designer creare prodotti che possano vivere a lungo, usando materiali più sostenibili, perfezionando gli stampi in modo da ridurre la quantità di plastica grazie i progressi della tecnologia.

L'esperienza e il know-how di Diemme danno la possibilità ai designer di avvalersi del supporto di tecnici specializzati, per qualunque specifica esigenza e in tutte le fasi di lavorazione dando loro il modo di utilizzare materiali innovativi e consente quindi ai clienti di entrare nel mondo green.

“Non dovremmo percepire una dissonanza tra il nostro desiderio di crescere e la qualità dell'ambiente che ci circonda”.

Real innovation makes it possible to meet both current and future needs. For this reason, Diemme places great emphasis on the durability its products and the materials used to make them. Thanks to our procurement policies and compliance with certification schedules, we can guarantee that purchased materials meet the conditions that the company has set itself in the fields of human rights and environmental standards. Creativity and experience come together in bringing to life innovative projects for total customer satisfaction and for eco-sustainability in terms of ease of disposal. It is the designer's responsibility to create products that can last, using ever more sustainable materials, refining moulds to reduce the amount of plastic thanks to technological advances. Diemme's experience and know-how give designers the opportunity to make use of specialised technical support, for any specification need and in all stages of the process, thereby giving them a way to use innovative materials and, as a result, allowing customers to enter the green world.

Une réelle innovation permet de répondre à la fois aux besoins actuels et futurs. C'est pourquoi la société DIEMME met l'accent sur la durabilité des produits et des matériaux utilisés pour les fabriquer. Grâce à nos politiques d'approvisionnement et au respect des délais dans la certification, nous garantissons que les matériaux achetés répondent aux conditions que l'entreprise s'est engagée à suivre dans le domaine des droits de l'homme et des normes environnementaux. La créativité et l'expérience se rejoignent dans la mise au point de projets innovants pour la satisfaction totale du client et pour l'éco-durabilité liée à la facilité d'élimination. Il est de la responsabilité du designer de créer des produits qui peuvent vivre longtemps, en utilisant des matériaux plus durables, en affinant les moules pour réduire la quantité de plastique grâce aux avancées technologiques. L'expérience et le savoir-faire de DIEMME donnent une chance aux designers de recourir à l'appui de techniciens spécialisés, pour tous besoins spécifiques et à toutes les étapes du traitement en leur donnant le moyen d'utiliser des matériaux innovants et permet ainsi aux clients d'entrer dans le monde Green.



UN IMPEGNO
CONCRETO

“L'essenza del futuro è voglia di produrre in modo green”



Senza compromettere né resa estetica, né resa funzionale, per la **Kire** in versione color Nero è stato utilizzato un polipropilene di nuova generazione interamente realizzato utilizzando fibre riciclate durevoli e ricche di risorse; il risultato finale è un materiale plastico con caratteristiche meccaniche e di tenuta pari ad una plastica vergine. Inoltre, l'estrema versatilità consente non solo di configurare un prodotto il più possibile aderente alle proprie esigenze, ma anche di modificare alcuni dettagli nel corso degli anni, massimizzandone il ciclo di vita e durata nel tempo.



Without compromising either aesthetic or functional performance, the black version of Kire uses a new generation polypropylene made entirely of durable recycled fibres and rich in resources; the final result is a plastic with mechanical and sealing characteristics equivalent to virgin plastic. Furthermore, this extreme versatility makes it not only possible to configure a product as closely as possible to one's needs, but also to tweak some details over the years, maximising its life cycle and durability.

Sans compromettre les performances esthétiques ou fonctionnelles, pour le Kire dans la version Black, il est utilisé un polypropylène de nouvelle génération entièrement fabriqué à partir de fibres recyclées durables et riches en ressources; le résultat final est une matière plastique avec des caractéristiques mécaniques et d'étanchéité égale à un plastique vierge. De plus, l'extrême versatilité permet non seulement de configurer un produit au plus près de vos besoins, mais aussi de faire évoluer certains détails au fil des années, maximiser son cycle de vie et sa durée dans le temps.

KIRE



Kire visitor chair / Cuoio Nero

Modern versatility

Kire è stata progettata per relazionarsi in modo più attuale e soft con lo spazio e con l'ambiente. Le nuove tonalità di colore introdotte, non si impongono, ma piuttosto si adattano a spazi ed ambienti anche molto diversi. La palette colori propone nuance gradevoli, che si ispirano alla natura e allo stesso tempo emotivamente attraenti. Il colore è ricordo ed emozione, il mattone e l'ocra richiamano i colori dell'argilla e della terra, l'azzurro e il verde le sfumature del mare. I colori influenzano anche l'umore e il benessere psicofisico, quelli della collezione Kire sono stati scelti rispettando questa filosofia.



Kire has been designed to relate with space and surroundings in a more contemporary and soft way. The newly introduced colourways are not overly bold, gently adapting to greatly differing spaces and settings. The colour range offers pleasant shades, inspired by nature and at the same time emotionally attractive. Colour is memory and emotion, brick and ochre evoke the colours of clay and earth, blue and green the shades of the sea. Colours also affect mood and psychophysical wellbeing, and those from the Kire collection have been chosen to respect this philosophy.

Kire a été conçu pour être en relation de manière plus contemporaine et douce avec l'espace ainsi qu'avec l'environnement. Les nouvelles nuances de couleurs introduites ne s'imposent pas, mais plutôt ils s'adaptent à des espaces et des environnements très différents. La palette de couleurs offre des nuances agréables, inspirées par la nature et en même temps émotionnellement attrayant. La couleur est mémoire et émotion, la brique et l'ocre rappellent les couleurs de l'argile et de la terre, le bleu et vert les nuances de la mer. Les couleurs affectent également l'humeur et le bien-être psychophysiques, ceux de la collection Kire ont été choisis avec le respect de cette philosophie.

“Versatilità è valore che esprimiamo in ogni nostro prodotto. Innumerevoli combinazioni di tessuti e colori rendono unica ogni esigenza progettuale”.

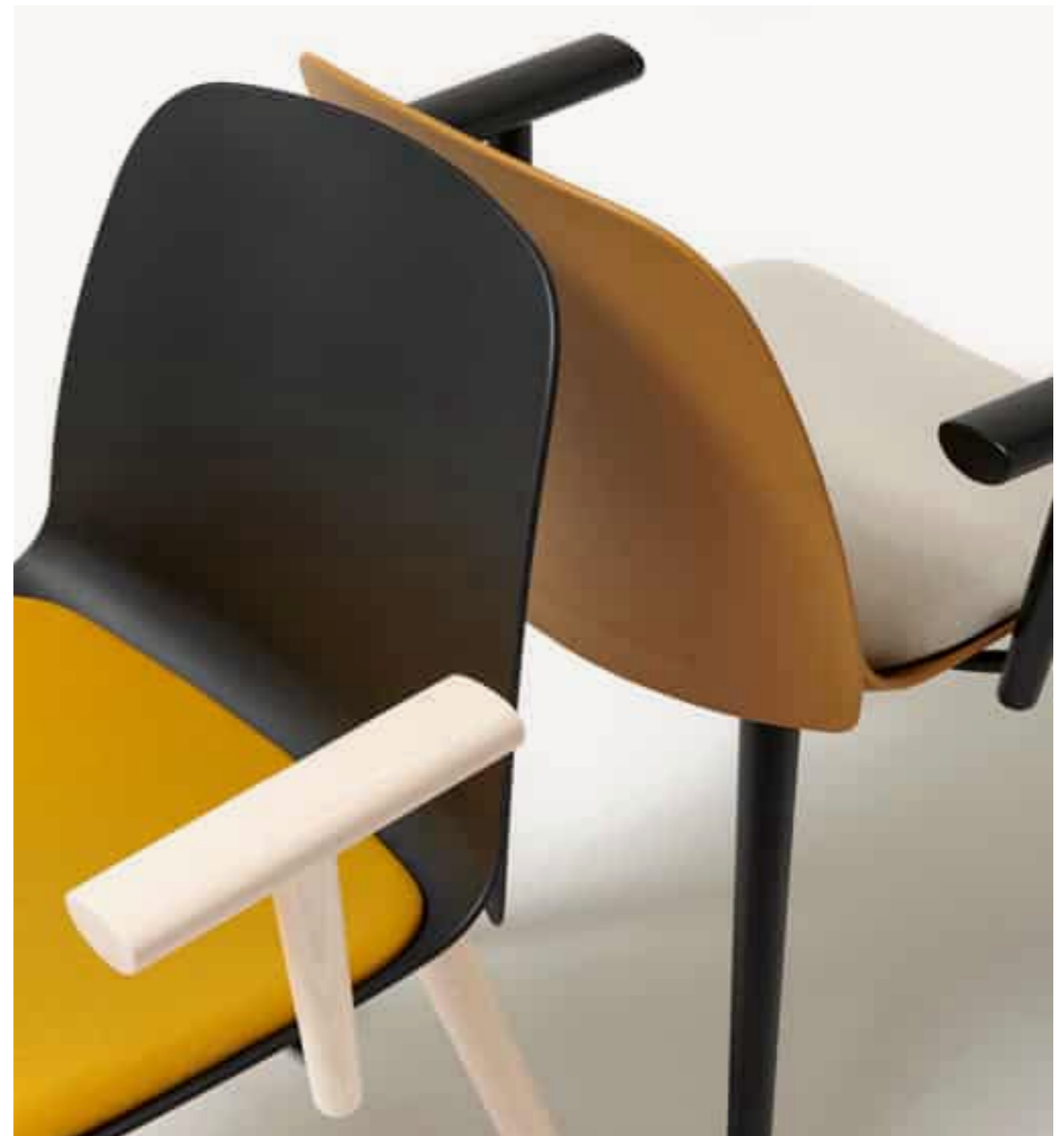





Kire community chair / Azzurro - Era CSE20



KIRE

KIRE



Kire task - visitor chair - stool / Azzurro / Azzurro - Jet 9110 / Azzurro - Jet 9110 / One 8032

KIRE



Kire task chair / Mattone - Jet 9110



KIRE

Giorgio Topan / 2022



Kire community chair / Azzurro - Jet 9110

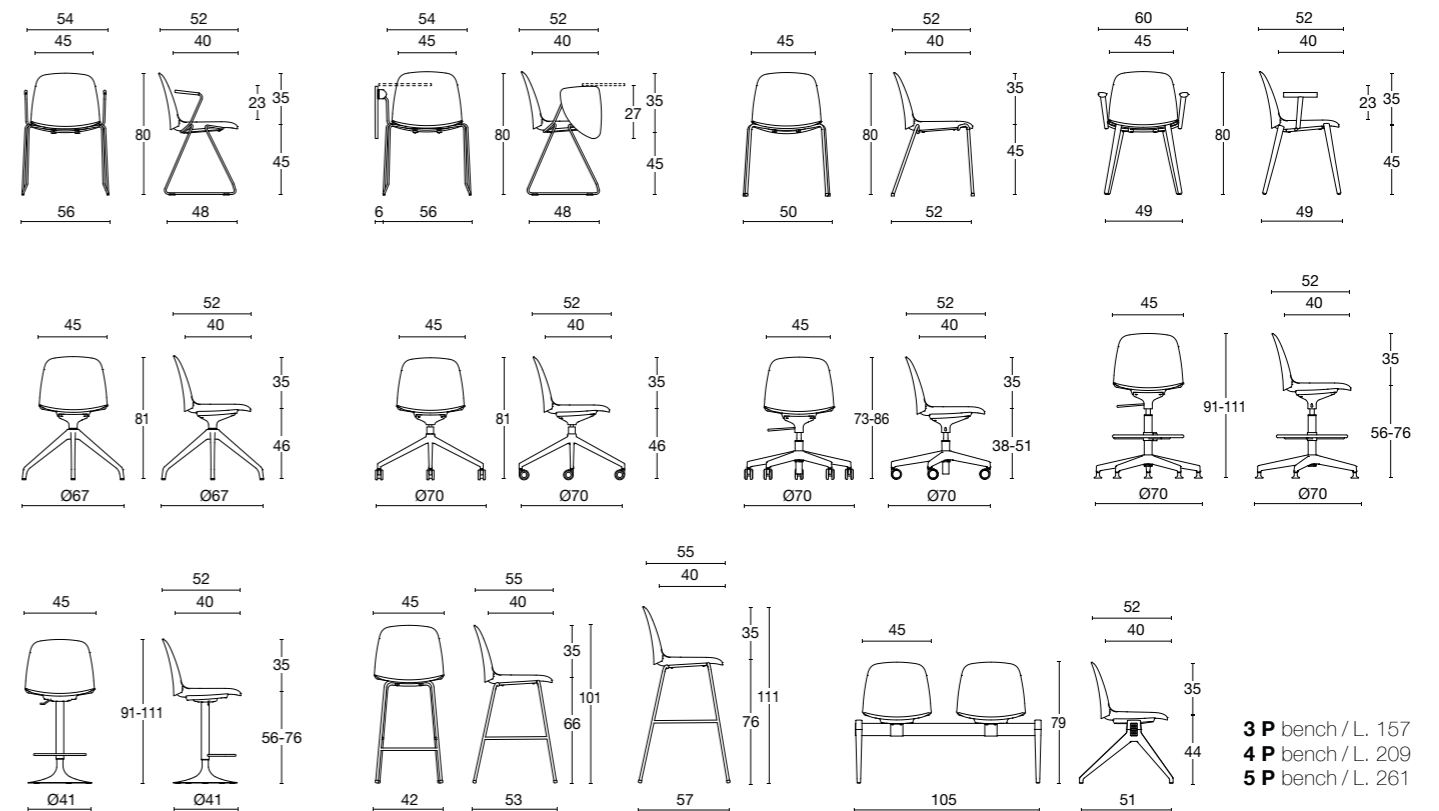

3 P bench / L. 157
4 P bench / L. 209
5 P bench / L. 261

La scocca in polipropilene è disponibile in 6 colori, può essere completamente rivestita, oppure con il solo cuscinetto sedile optional. La gamma comprende la versione fissa su telaio 4 gambe o slitta, bianco, nero o cromato, impilabile. La versione slitta disponibile con braccioli completi di top in poliuretano, colore nero o bianco e bracciolo con tavoletta scrittoio, impilabile. Basamento 4 gambe in legno frassino naturale o verniciato nero, disponibile anche con braccioli. La versione girevole su basamento in polipropilene piramidale bianco o nero, su basamento piramidale in alluminio lucido, nero o bianco su ruote. Disponibile la versione 5 razze in polipropilene bianco e nero con elevazione gas. 3 sono le diverse possibilità di sgabello, operativo 5 razze, girevole con gas e 4 gambe nero o bianco di due diverse altezze. Versione panca da 2 a 5 posti.

Polypropylene chair with clean design and innovative personalised detail in the backrest. The polypropylene shell is available in 6 different colours; it can be completely upholstered; or have a seat-cushion only. The range includes the fixed stacking versions with white, black or chromed sled or four-legged frames. The sled version is available with armrests with black or white polyurethane tops, an armrest with writing tablet, and remains stackable. The 4-legged version with natural or black lacquered ashwood shell is also available with armrests. The pyramid version comes: on a black or white polypropylene base; on a black, white or polished aluminium base; optionally with castors. A black or white polypropylene 5-spur height-adjustable version is also available. There are three stool versions: five-spur task; swivel with height-adjustment; and 4 black or white legs available at a choice of seat heights. Beam units with 2 to 5 seats.

Chaise en polypropylène au design essentiel, avec des détails innovants et personnalisés dans son dossier. Son corps en polypropylène est disponible en 6 couleurs différentes, il peut être entièrement rembourré ou avec seulement le coussin d'assise optionnel. La gamme comprend la version fixe sur châssis 4 pieds ou traîneau, blanc, noir ou chromé, empilable. La version traîneau disponible avec accoudoirs complets avec manchette en polyuréthane, noir ou blanc et accoudoir avec tablette écriteure, empilable. Base à 4 pieds en bois de frêne naturel ou peint en noir, également disponible avec accoudoirs. La version pivotante sur socle en polypropylène pyramidal blanc ou noir, sur socle pyramidal en aluminium poli, noir ou blanc sur roulettes. Disponible dans la version 5 branches en polypropylène noir et blanc avec élévation à gaz. 3 versions différentes de tabourets, opératif à 5 branches, pivotant à gaz et 4 pieds noirs ou blancs de deux hauteurs différentes. Version banquette de 2 à 5 places.

-  **struttura**
polipropilene
-  base cromata / verniciata bianca, nera o su richiesta in colore / polipropilene bianco o nero / alluminio lucido / legno frassino naturale o verniciato nero
-  **rivestimento**
tessuto
-  pelle
ecopelle
cuoio

- frame**
polypropylene
- base chromed / painted white, black or on request in color / white polypropylene or black / polished aluminum / ash wood natural or black painted
- upholstery**
fabric
- genuine leather
faux leather
hide

- structure**
polypropylène
- piètement chromé / laqué blanc, noir ou sur demande en polypropylène couleur / blanc ou noir / aluminium poli / bois de frêne naturel ou peint en noir
- revêtement**
tissu
- cuir
simili cuir
sellier

Rivestimenti

Upholstery | Nuanciers

JET / CAT. F

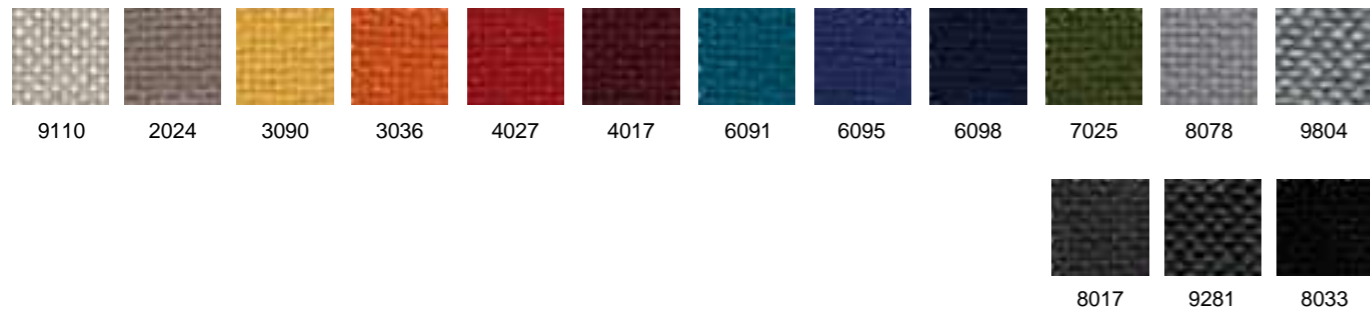

CUBE / CAT. G

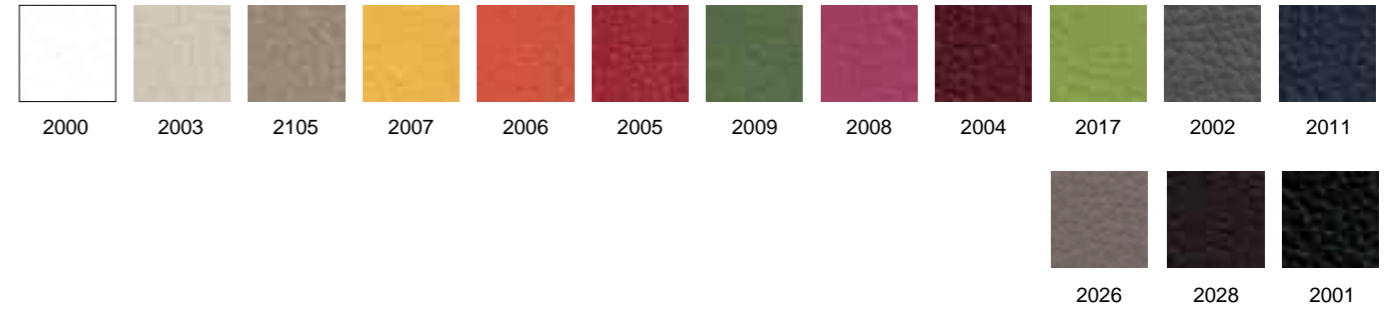

PLANET - SURROUND / CAT. F

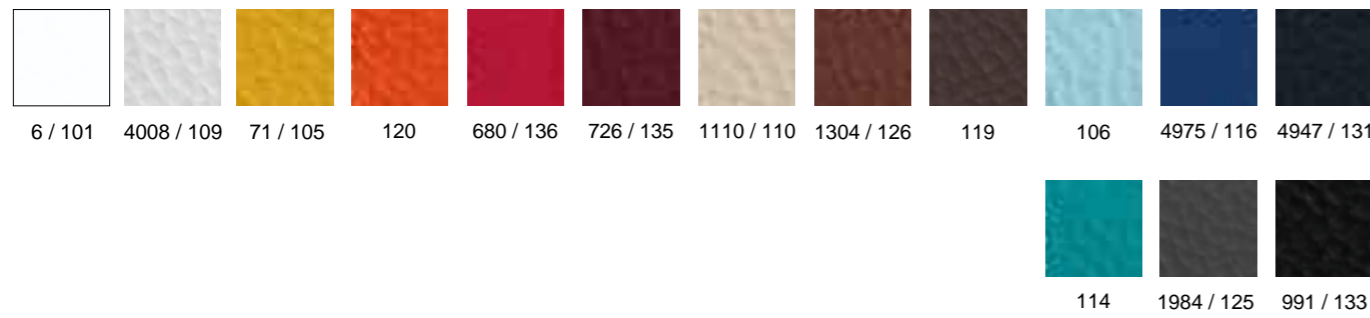

ERA / CAT. S

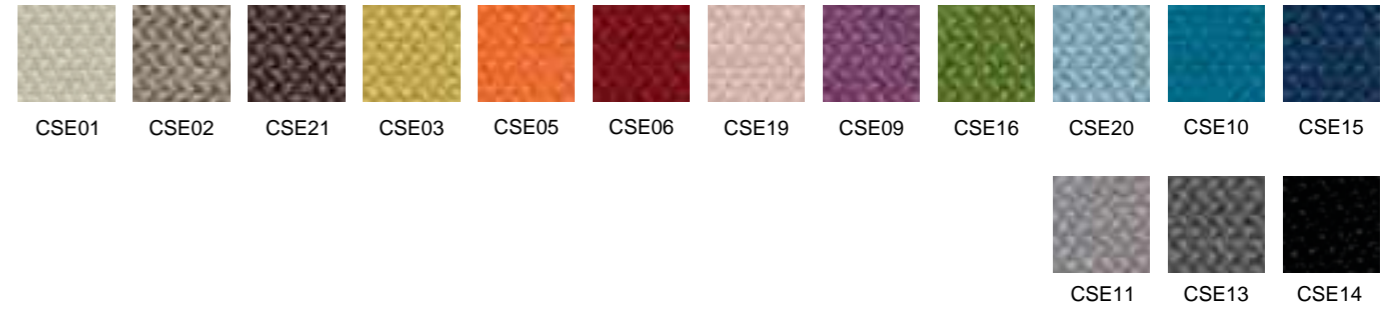

ONE / CAT. G

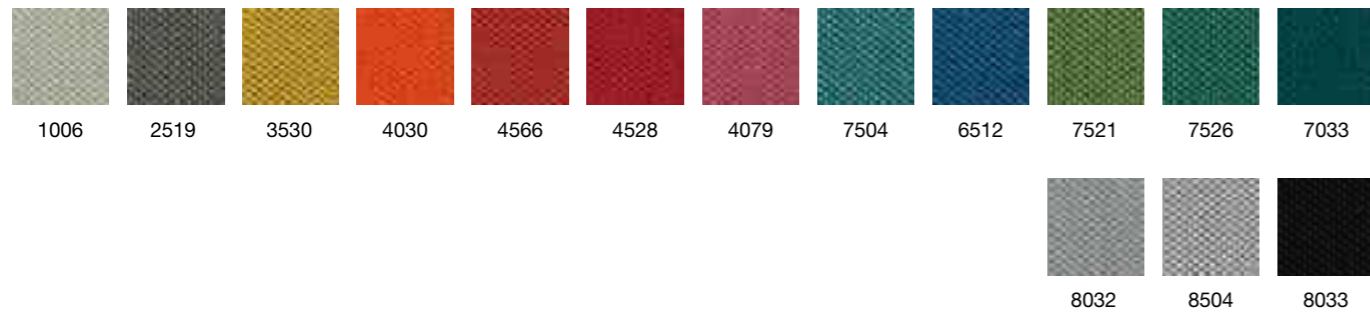

IKON / CAT. TOP

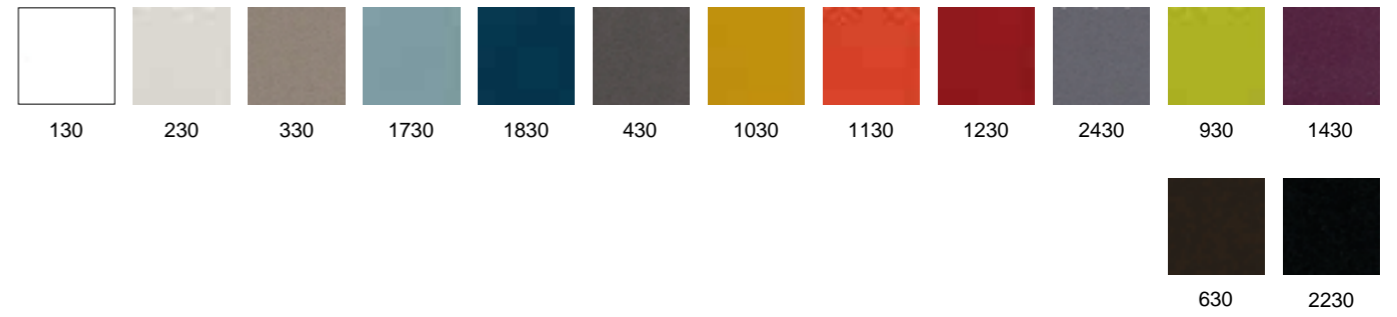

BINGO ELAST - MIRAGE / CAT. G

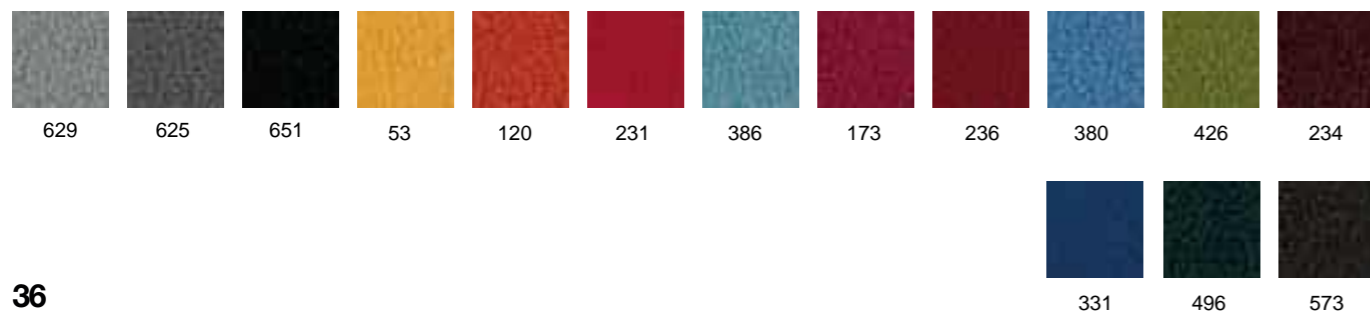

BLAZER / CAT. EXTRA



GORGEOUS / CAT. EXTRA

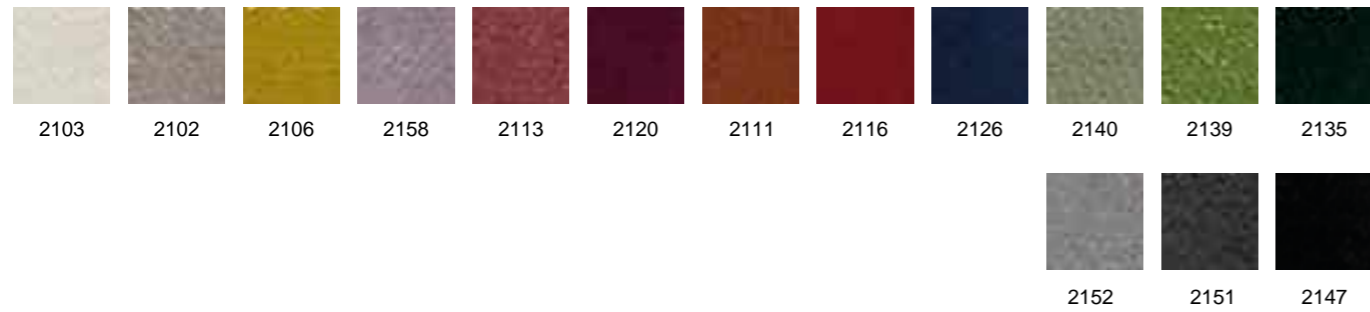

HESTAN / CAT. EXTRA

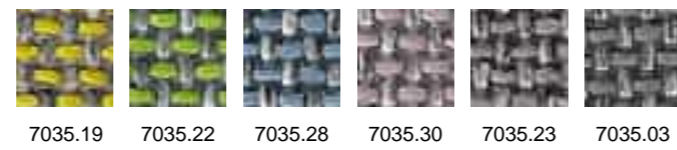

WOLIN / CAT. EXTRA



POLO / CAT. FIESTA

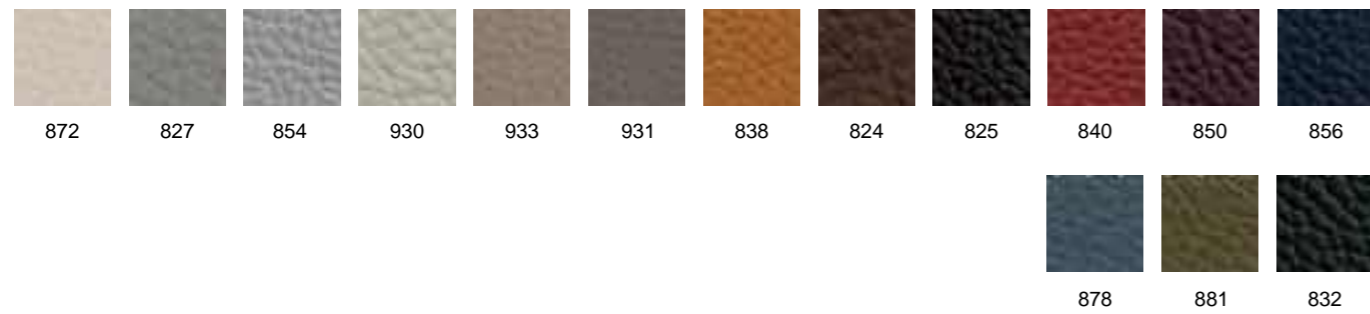

FIESTA

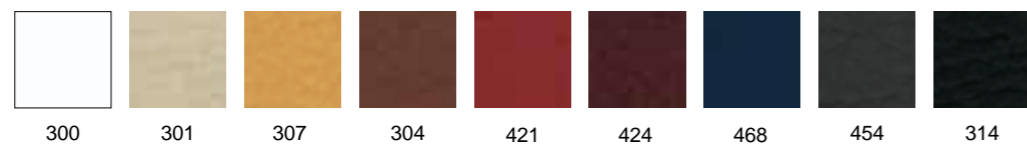

NUVOLA

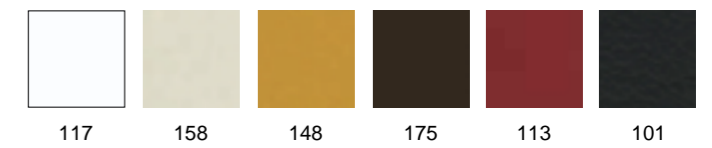

SEDIA IN CUOIO | Hide | Cuir sellier / KIRE



POLIPROPILENE | Polypropylene | Polypropylène / KIRE

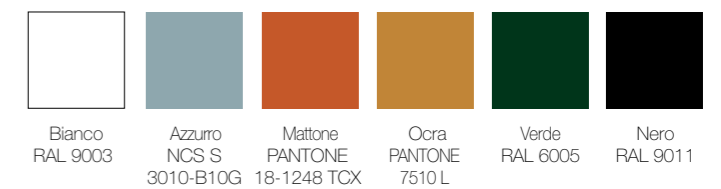



Distributor pro ČR a SK
www.mintiga.cz
obchod@mintiga.cz
+420 724 124 042

Art direction: Priority Design
Graphic design concept: Priority Design
Photo: Arch. Prior Vinicio
Styling: Baliviera Enrica
Post production: Priority Design

Diemme Srl
Via del Lavoro, 25 | 31013 Codognè TV | Italy
T. +39 0438 778211
F. +39 0438 479836

dm@diemmeoffice.com
www.diemmeoffice.com

2

furniture to
connect people

Lavoriamo dove siamo nati

We work where we were born | Nous travaillons où nous sommes nés

4

Comfort e Sostenibilità

Comfort and Sustainability | Confort et Durabilité

6

Collezioni

Collections | Les Collections

9

Rivestimenti

Upholstery | Nuanciers

197

LAVORIAMO
DOVE
SIAMO NATI

WE WORK
WHERE
WE WERE
BORN

NOUS
TRAVAILLONS
OÙ NOUS
SOMMES NÉS

Non abbiamo mai inaugurato ufficialmente Diemme, sarebbe come dire: “Missione compiuta... lavoro terminato... possiamo rilassarci”.

Finirebbe per intorpidirci, quando invece per noi Diemme è un progetto in continua evoluzione, su cui riversare la nostra dedizione ogni giorno. Dopo più di vent’anni di attività ci sentiamo a casa.

Ci siamo conosciuti nel 1985. Entrambi lavoravamo nel settore dell’imbottito, ma in due aziende diverse. Poi siamo diventati colleghi. Nel corso del tempo si è creato tra noi un rapporto di profondo rispetto e amicizia, indispensabile per intraprendere un’attività insieme. Nel 1995 in una giornata fredda d’inverno, dopo una delle nostre lunghe chiacchierate, abbiamo deciso di unire le forze e dar vita a Diemme.

L’azienda nasce lavorando per conto di terzi, ma la nostra visione è sempre stata quella di dedicarci alla creazione di un sistema coerente di sedute tutte nostre. Dopo aver disegnato e realizzato con passione la nostra prima seduta da ufficio, è stato chiaro che quella era la strada da seguire. In poco tempo è uscito il nostro primo catalogo, a cui hanno fatto seguito i primi successi. Come dimenticare la nostra prima fiera. Sono passati molti anni, ma il ricordo di vedere i nostri prodotti introdotti nel mondo office rimane indelebile.

Come tutti, anche noi abbiamo attraversato gli anni della crisi, ma siamo ugualmente cresciuti grazie a scelte coraggiose e ben precise: collaborare con architetti e designer, e ampliare la visione del mondo office affiancando divani e poltroncine alle sedute che già producevamo.

La forza di Diemme è ciò che ci circonda: il territorio in cui siamo nati e in cui ancora operiamo, i nostri partner locali, le persone che ci sono sempre state vicino. Grazie a loro abbiamo trovato il coraggio di guardare lontano, affrontare nuovi progetti, aprirci a nuovi mercati.

Siamo rimasti umili e concreti, ma allo stesso tempo ambiziosi di trasformare le nostre collezioni in un sistema di prodotti versatili e adatti ad ogni ambiente. Forse può sembrare un luogo comune, ma due menti sono davvero meglio di una. Esperienze diverse, punti di vista diversi, personalità diverse; Diemme è cresciuta come azienda perché ci siamo sempre impegnati a vedere oltre alle nostre differenze e a trovare un punto d’unione. Questo è il nostro pensiero.

We have never officially inaugurated Diemme, it would be like saying: “Mission accomplished... job done... time to relax”. It would end up numbing us, when instead, to our way of thinking, Diemme is a project in continuous evolution, which we smother with our dedication every day. After more than twenty years of activity, we feel at home.

We met in 1985, we both worked in the upholstery trade, but in two different companies. Then we became colleagues. Over time, a relationship of deep respect and friendship developed between us, essential for embarking on any joint venture. On a cold winter’s day in 1995, after one of our long chats, we decided to join forces and give life to Diemme.

At first, Diemme worked for third parties, but our vision was always to dedicate ourselves to creating a coherent seating system all our own. After designing and creating our first office chair with passion, it was clear that this was the way forward. In a short time our first catalogue was released, followed by the first successes. How can we forget our first fair. Many years have passed, but the memory of seeing our products introduced into the office world remains indelible.

Like everyone else, we too have gone through the years of crisis, but we have equally grown thanks to courageous and precise choices: collaborating with architects and designers, and widening the vision of the office world by introducing sofas and armchairs alongside the seating we already produced. The strength of Diemme is what surrounds us: the territory in which we were born and where we still operate, our local partners, the people who have always been close to us. Thanks to them, we found the courage to look far, face new projects, open up to new markets. Though remaining humble and concrete, we are at the same time ambitious to transform our collections into a system of versatile products suited to any environment. It may sound like a cliché, but two heads really are better than one. Different experiences, different points of view, different personalities; Diemme has grown as a company because we have always been committed to seeing beyond our differences and finding a meeting point. This is the way we see it.

Nous n’avons jamais officiellement inauguré Diemme, ce serait comme dire: “Mission accomplie... travail terminé... on peut se détendre”. Cela finirait par nous engourdir, alors qu’au contraire pour nous Diemme est un projet en évolution continue, sur lequel verser notre dévouement quotidien. Après plus de vingt ans d’activité, nous nous sentons chez nous.

Nous nous sommes rencontrés en 1985, nous travaillions tous les deux dans le secteur du rembourrage, mais dans deux entreprises différentes. Ensuite, nous sommes devenus collègues. Au fil du temps, une relation de profond respect et d’amitié s’est nouée entre nous, indispensable pour entreprendre ensemble une entreprise. En 1995, par une froide journée d’hiver, après l’une de nos longues conversations, nous avons décidé d’unir nos forces et de donner vie à Diemme.

L’entreprise a été fondée en travaillant pour des autres sociétés, mais notre vision a toujours été de créer un système cohérent de sièges qui nous est propre. Après avoir conçu et créé notre premier siège de bureau avec passion, il était clair que c’était la voie à suivre. En peu de temps, notre premier catalogue est sorti, suivi des premiers succès. Comment oublier notre première foire. De nombreuses années ont passé, mais la mémoire de voir nos produits introduits dans le monde du bureau reste indélébile.

Comme tout le monde, nous avons aussi traversé les années de la crise, mais nous nous sommes également développés grâce à des choix courageux et précis: collaborer avec les architectes et les designers, élargir la vision du monde du bureau en plaçant canapés et fauteuils à côté des sièges que nous avons déjà produits. La force de Diemme, c’est ce qui nous entoure: le territoire dans lequel nous sommes nés et dans lequel nous opérons encore, nos partenaires locaux, les gens qui ont toujours été proches de nous. Grâce à eux, nous avons trouvé le courage de regarder loin, de faire face à de nouveaux projets, de nous ouvrir à de nouveaux marchés. Nous sommes restés humbles et concrets, mais en même temps ambitieux de transformer nos collections dans un système de produits polyvalents adaptés à tout environnement. Cela peut sembler banal, mais deux esprits valent vraiment mieux qu’un. Différentes expériences, différents points de vue, différentes personnalités; Diemme a grandi parce que nous nous sommes toujours engagés à voir au-delà de nos différences et à trouver un point de rencontre. Telle est notre pensée.

COMFORT E SOSTENIBILITÀ

L'innovazione vera e propria permette di soddisfare le esigenze sia attuali che future.

Siamo chiamati ad affrontare le sfide quotidiane con atteggiamento reattivo e propositivo, andando alla ricerca di nuove soluzioni creative senza soffermarci per inerzia su procedimenti obsoleti. Gli spazi entro cui ci muoviamo devono, quindi, plasmarsi su di noi perché si crei una sinergia tra pensiero ed espressione, interiorità ed esteriorità. Non dovremmo percepire alcuna dissonanza tra il nostro desiderio di crescere e la qualità dell'ambiente che ci circonda.

Ogni giorno ci mettiamo in gioco per facilitare e migliorare la vita di altre persone. Proprio per questa ragione, lo spazio intorno a noi non deve adattarsi solo alle nostre esigenze correnti ma anche ai bisogni delle generazioni future.

Scegliere una seduta che garantisce un supporto corretto è un modo semplice e diretto di migliorare la qualità del tempo e favorire il benessere. Per garantire questo servizio, eseguiamo controlli in tutte le fasi di produzione seguendo un sistema di gestione della qualità certificato ISO 9001. Oltre a offrire il giusto supporto ergonomico, proponiamo ampie possibilità di personalizzazione per rispondere al bisogno umano, sempre sentito, di unicità e bellezza.

Ci assicuriamo che tutti i materiali che utilizziamo siano di origine locale per ridurre gli sprechi e favorire quindi la crescita di un mercato "verde". In fase di progettazione, cerchiamo i percorsi migliori per realizzare prodotti a ridotto impatto ambientale lungo l'intero ciclo di vita. Grazie a queste accortezze, semplici ma significative, due delle nostre sedute hanno ottenuto la certificazione promossa dal Green Public Procurement, ovvero il nuovo approccio Europeo agli acquisti ecosostenibili.

COMFORT AND SUSTAINABILITY

True innovation should meet both current and future needs.

We are called to face daily challenges with a reactive and proactive attitude, going in search of new creative solutions without dwelling on inertia on obsolete procedures. The spaces in which we move must, therefore, mold themselves around us to create a synergy between thought and expression, interior and exterior. We should not perceive any friction between our desire to grow and the quality of the environment around us.

Every day we roll our sleeves up to facilitate and improve the lives of other people. Precisely for this reason, the space around us ought not only to adapt to our current needs but also to those of future generations.

Choosing a chair that guarantees correct support is a simple and direct way of improving the quality of time and promoting well-being. To ensure this, we carry out checks at all stages of production following an ISO 9001 certified quality management system. In addition to offering the right ergonomic support, we offer extensive customization options to respond to the ever-present human hunger for uniqueness and beauty.

We make sure that all the materials we use are of local origin to reduce waste and therefore encourage the growth of a "green" market. During the design phase, we look for the best ways to create products with reduced environmental impact throughout their entire life cycle. Thanks to these simple but significant precautions, some Diemme chairs have obtained Green Public Procurement certification, being the new European approach to eco-sustainable purchases.

CONFORT ET DURABILITÉ

L'innovation actuelle nous permet de répondre aux besoins actuels et futurs.

Nous sommes appelés à faire face aux défis quotidiens avec une attitude réactive et proactive, à la recherche de nouvelles solutions créatives sans insister sur les procédures obsolètes. Les espaces dans lesquels nous évoluons doivent donc se modeler sur nous afin de créer une synergie entre pensée et expression, intériorité et extériorité. Nous ne devons percevoir aucune dissonance entre notre envie de grandir et la qualité de l'environnement qui nous entoure.

Chaque jour, nous nous impliquons pour faciliter et améliorer la vie des autres. C'est précisément pour cette raison que l'espace qui nous entoure doit non seulement s'adapter à nos besoins actuels mais aussi aux besoins des générations futures.

Choisir un siège qui garantit un soutien correct est un moyen simple et direct d'améliorer la qualité du temps et de favoriser le bien-être. Pour garantir ce service, nous effectuons des contrôles à toutes les étapes de la production selon un système de gestion de la qualité certifiée ISO 9001. En plus d'offrir le bon support ergonomique, nous proposons de nombreuses options de personnalisation pour répondre au besoin humain d'unicité et de beauté.

Nous prenons garde à tous les matériaux que nous utilisons qu'ils soient d'origine locale pour réduire les déchets et donc favoriser la croissance d'un marché «vert». Pendant la phase de conception, nous recherchons les meilleures façons de créer des produits à impact environnemental réduit tout au long du cycle de vie. Grâce à ces précautions simples mais importantes, certains de nos sièges ont obtenu la certification promue par Green Public Procurement, qui est la nouvelle approche européenne pour les achats éco-durables.

COMMUNITY



CLOP

15



ORIGAMI

25



PASS

33



SOCIAL

41

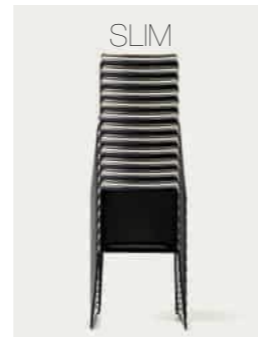

SLIM

49



SUNNY NEW

59



NEW BOMBI

67



NO FRILL

79

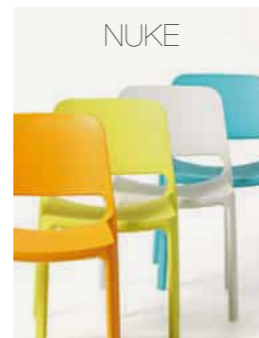

NUKE

89



CLOP

99



CLEA

111

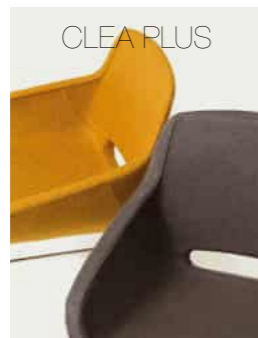

CLEA PLUS

121



MISS

129



EON

141



VANITY

155



MARGARITA

165

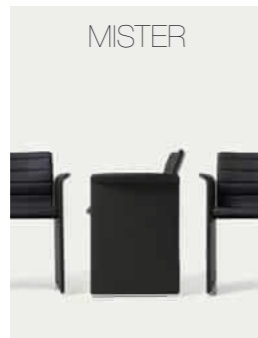

MISTER

173

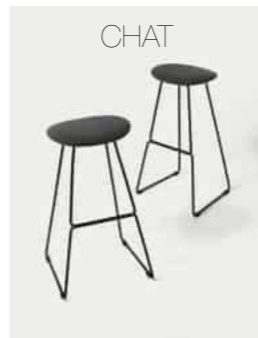

CHAT

179

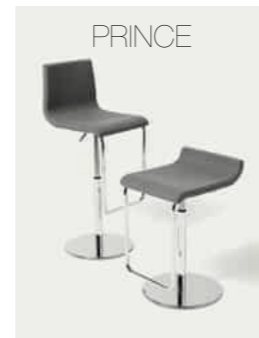

PRINCE

185



RED HOT

191

Collezioni

Collections | Les collections

Non esistono spazi neutrali. Quando entriamo in un luogo già popolato da altre persone, la disposizione di ognuna di loro nei confronti dello spazio è uno dei fattori che determinano la qualità della nostra permanenza al suo interno. Per questo motivo, quando progettiamo un nuovo prodotto, noi di Diemme partiamo da un semplice assioma: tutte le persone, dal momento in cui entrano nella stanza al momento in cui escono, devono sentirsi comode e tranquille.

Vogliamo favorire il comfort in tutti gli ambienti collettivi: quelli in cui le persone semplicemente transitano, quelli in cui sono chiamate a confrontarsi e relazionarsi, quelli in cui si riuniscono perché desiderano trascorrere del tempo insieme.

Ogni spazio si carica di significati aggiunti perché portiamo con noi emozioni, ricordi e abitudini ovunque andiamo.



“Quando entriamo in un luogo già popolato da altre persone, la disposizione di ognuna di loro nei confronti dello spazio è uno dei fattori che determinano la qualità della nostra permanenza al suo interno.”

COMMUNITY



There are no neutral spaces. Whenever we enter a place where there are already other people, the position of each of them in relation to the space is one of the factors that determine the quality of the time we spend there. For this reason, when we design a new product, we at Diemme start from a simple axiom: everyone has to feel calm and comfortable from the moment they enter a room until the moment they leave. We want to promote comfort in all communal settings: those where people merely pass on through, those where they need to discuss and decide, those where they gather because they want to spend time together. Each space is loaded with added meanings because we bring emotions, memories and habits with us wherever we go.

Il n'y a pas d'espaces neutres. Lorsque nous entrons dans un lieu déjà peuplé par d'autres personnes, l'arrangement de chacun d'eux vers l'espace est l'un des facteurs qui déterminent la qualité de la notre permanence à l'intérieur. C'est pour cette raison que, lorsque nous concevons un nouveau produit, chez Diemme, nous partons d'un simple axiome: toutes les personnes, dès leur entrée dans la pièce à leur sortie, se doivent de se sentir à l'aise et calme. Nous voulons promouvoir le confort dans tous les environnements collectifs: ceux dans lesquels les gens transitent, ceux dans lesquels ils sont appelés à se rapporter aux autres, ceux où ils se rencontrent parce qu'ils veulent passer du temps ensemble. Chaque espace est chargé de significations ajoutées parce que nous apportons avec nous des émotions, des souvenirs et des habitudes partout où nous allons.

“È necessario ripensare agli spazi dedicati alle attività di piccoli gruppi quali progetti, discussioni, lettura o scrittura, formazione e insegnamento. L’arredo deve essere facilmente ricombinabile ed estremamente flessibile per trasformare gli ambienti in incubatori di nuove idee, favorendo la creazione di una cultura condivisa.”

Collettività

Community | Chaises de collectivité

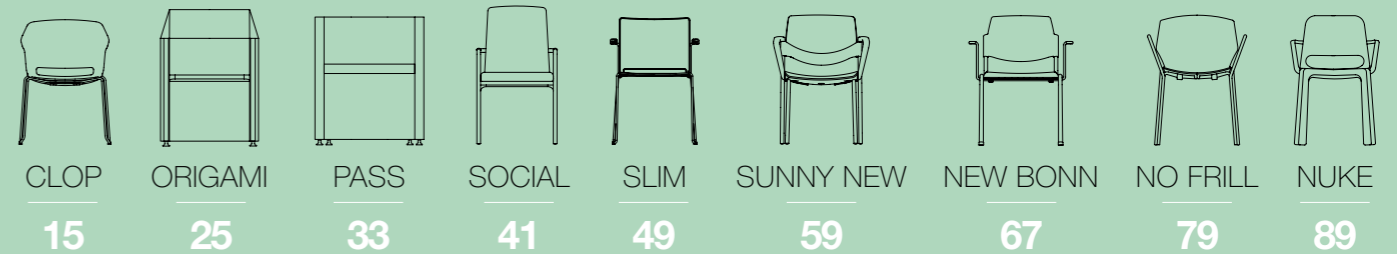

“Small group spaces for activities such as projects, meetings, reading or writing; education and training need to be rethought; furnishings need to be flexible and easy to reconfigure flexible so that they can become breeding grounds for new ideas stemming from a shared culture.”

“Les espaces dédiés aux activités en petits groupes comme les projets, discussions, lecture ou écriture, formation et enseignement il faut les repenser; les meubles doivent être recombinés et extrêmement flexibles en les transformant les espaces dans les incubateurs de nouvelles idées, en favorisant la perception d’une culture partagée.”

Disegnata da DorigoDesign,
CLOP si contraddistingue
per le linee leggere e avvolgenti.
Il suo design vintage si combina
a un'attitudine contemporanea
al servizio della fruibilità e dell'ergonomia.
Per la collettività, Clop è disponibile
con tavoletta e in versione panca.

CLOP

DorigoDesign / 2018

15

CLOP

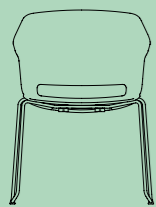

Designed by DorigoDesign, CLOP is distinguished by its slender lines and enveloping feel. Its vintage design combines with a contemporary attitude to make Clop a handy and ergonomic choice. For contract use, Clop is available with writing tablet and on beam.

Conçu par DorigoDesign, CLOP se distingue par ses lignes légères et sa sensation enveloppante donnée par la coque. Son design vintage se conjugue avec une attitude contemporaine qui met Clop au service de la convivialité et de l'ergonomie. Pour la communauté, Clop est disponible avec tablette et en version poutre.



Clop community chair / Verde - Hestan 7035.22 / Bianco / Bianco - Mirage 496 / Verde - Mirage 496

CLOP

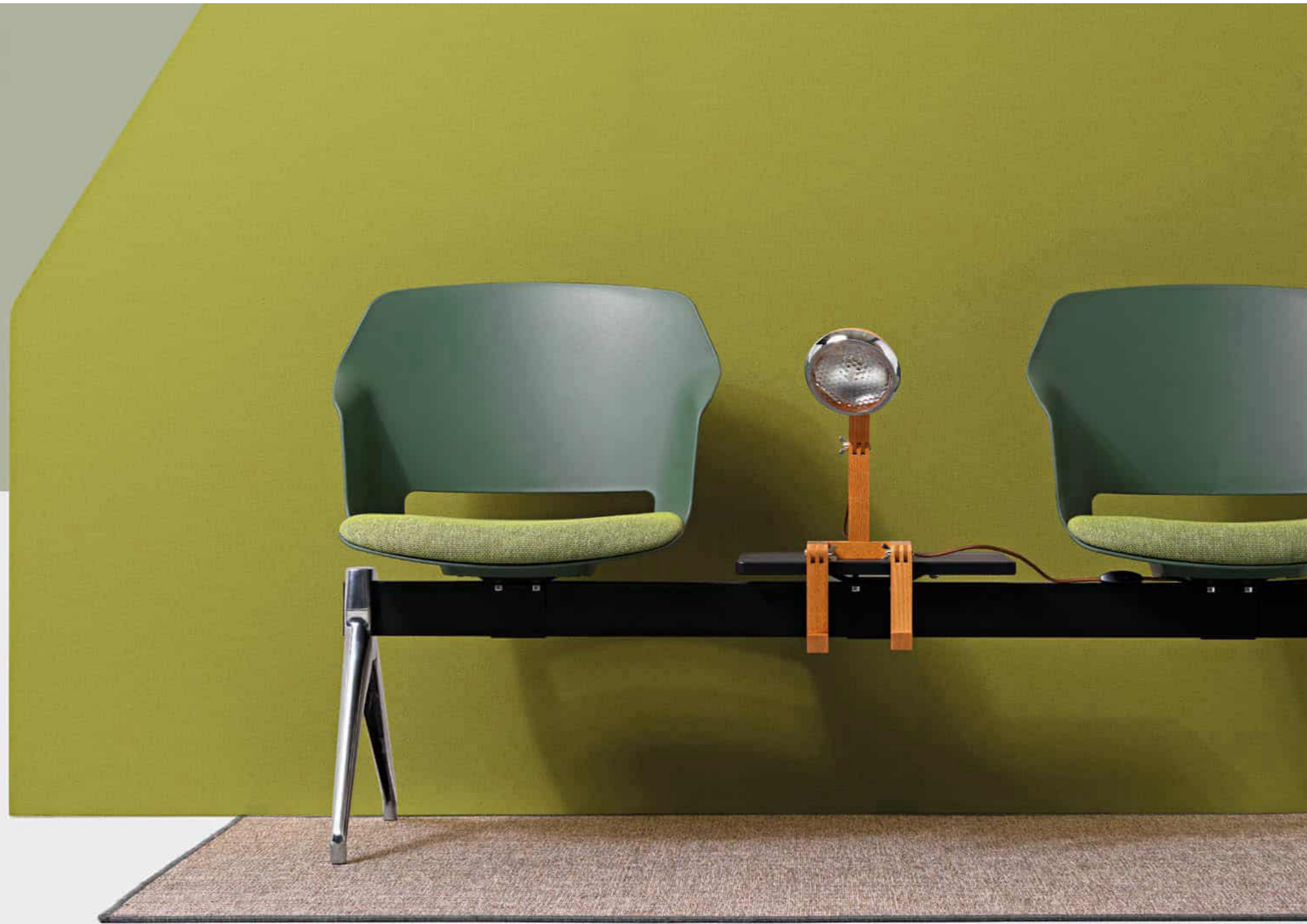

Clop community chair / Verde - Hestan 7035.22

CLOP



CLOP

DorigoDesign / 2018

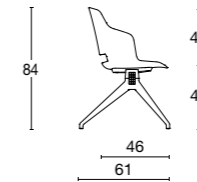
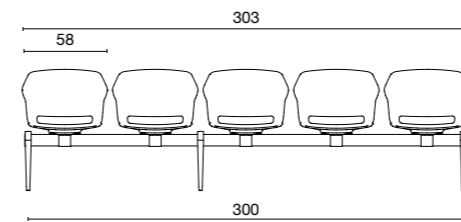
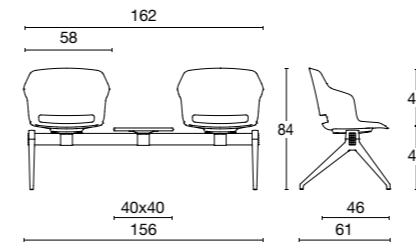
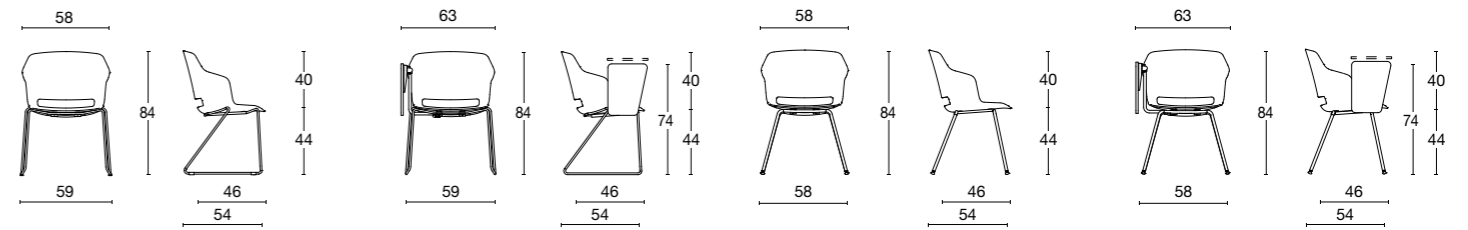

2 P bench / L. 119
3 P bench / L. 181
4 P bench / L. 242

Poltroncina dal design innovativo e dalle linee leggere, la scocca è in polipropilene disponibile in diversi colori. Può essere completamente rivestita, oppure con solo il cuscinetto sedile. La gamma comprende la versione fissa su telaio 4 gambe o slitta, bianco, nero o cromato. La variante su panca da 2/3/4/5 posti. Optional: tavoletta scrittoio in polipropilene. Altre varianti del modello sono incluse nelle sezioni operative e attesa.

An armchair with an innovative design and clean lines; four-legged and sled-based versions, chromed, black or white. The beam system is available as two, three, four and five-seaters. Optional: polypropylene writing tablet. Other versions and frame types are included in the task chairs and meeting sections.

Fauteuil au design innovant et aux lignes légères, la coque est en polypropylène disponible en différentes couleurs. Il peut être complètement couvert ou avec seulement le coussin d'assise. La gamme comprend la version fixe sur piètement 4 pieds ou luge, blanc, noir ou chromé. La variante sur poutre 2/3/4/5 places. Accessoire: tablette écriteiro en polypropylène noir. D'autres variantes du modèle sont incluses dans les sections opératif et visiteur.



struttura
polipropilene



base cromata / verniciata nera / verniciata bianca / alluminio



rivestimento
tessuto



pelle
ecopelle

frame

polypropylene

base: chromed / black lacquered / white lacquered / polished aluminium

upholstery

fabric

genuine leather
faux leather

structure

polypropylène

base aluminium / blanche / noire ou chromée

revêtement

tissu

cuir
simili cuir

La struttura di **ORIGAMI**
si basa sulla geometria delle forme.
Il design è sottile e funzionale.
Per favorire l'ottimizzazione degli spazi,
le sedute sono completamente richiudibili
e impilabili orizzontalmente.
Adatte per sale conferenza eleganti
ed efficienti.

ORIGAMI

Diemme Lab / 2013

25

ORIGAMI

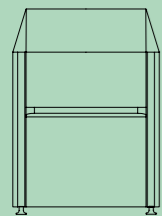

The structural principle of ORIGAMI is the geometry of its design. Origami chairs are extremely practical and their design is subtle and functional. This space-saving creation can be folded away in a jiffy and then stacked sideways by means of a hook at the base. Origami is especially designed for elegant and efficient conference rooms.

Le principe structurel d'ORIGAMI est la géométrie du dessin. Les petits fauteuils Origami sont extrêmement pratiques et leur design est mince et fonctionnel. Pour faciliter l'optimisation des espaces, les sièges peuvent être complètement pliés en quelques gestes et ils sont empilables horizontalement. Ils sont spécialement conçus pour les salles de conférence élégantes et efficaces.



ORIGAMI

Diemme Lab / 2013



Origami community armchair / Blazer CUZ30 - CUZ82 - CUZ28

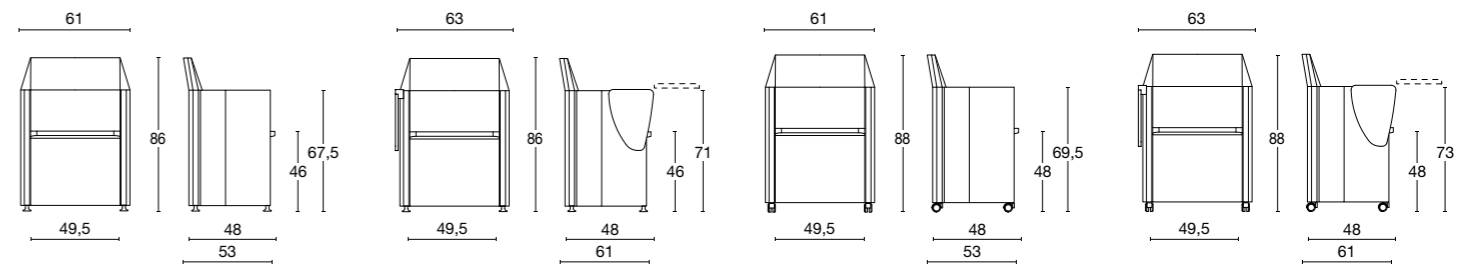

Pozzetto, ideale per sale conferenze, riunioni e d'aspetto. Interno in acciaio e imbottitura in schiumato a freddo. Richiudibile e impilabile orizzontalmente. Su ruote o piedini. Optional: tavoletta scrittoio.

Mini-tub chair, ideal for conference, meeting and waiting areas. Steel inner frame with cold foam padding. Foldable and sideways stackable. On wheels or floorpads. Optional: writing tablet.

Siège idéal pour les salles de conférence, de réunion et d'attente. Intérieur en acier et mousse moulée à froid. Pliable et empilable horizontalement. Sur roulettes ou sur pieds. Accessoire: tablette écriteiro.



struttura
acciaio



piedini in polipropilene o ruote



rivestimento
tessuto



pelle
ecopelle

frame
steel

polypropylene floorpads or castors

upholstery
fabric

genuine leather
faux leather

structure
acier

pieds en polypropylène ou roulettes

revêtement
tissu

cuir
simili cuir

PASS porta una ventata d'aria fresca al classico modello delle sedute a pozzetto.

Elegante e versatile, ha una forma tondeggiante e confortevole.

La parte superiore liscia le permette di essere inserita sotto al tavolo da riunione.

Pass entra facilmente in tutti gli ambienti. Il suo inserto laterale crea giochi di colore personalizzati.

PASS

Diemme Lab / 2012

33

PASS

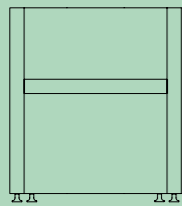

PASS brings a breath of fresh air to the classic tub-chair. Its comfy rounded shape and flattened upper part allow it to slide completely under a meeting table. Elegantly versatile, Pass slots handily into both funky and formal settings, and the outer shell can come in jazzy colour combinations.

PASS apporte une bouffée d'air frais au modèle classique du fauteuil. Élégant et polyvalent, il a une forme arrondie et confortable. Le fauteuil peut être inséré sous la table de réunion. Pass s'harmonise facilement dans tous les environnements. Son insert latéral crée jeux de couleurs personnalisables.

PASS



Pass community chair / Gorgeous 2111

PASS

Diemme Lab / 2012



Pass community chair / Gorgeous 2106

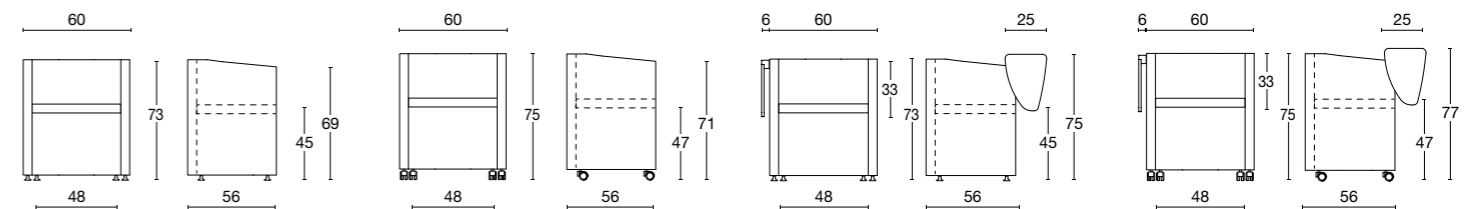

Pozzetto, ideale per sale riunioni e d'aspetto. Interno in legno con imbottitura in poliuretano espanso, con braccioli. Su ruote o piedini. Optional: tavoletta scrittoio.

Mini-tub chair, ideal for conference, meeting and waiting areas. Wood inner frame with polyurethane foam padding. On wheels or floorpads. Optional: writing tablet.

Mini-tub chair, ideal for conference, meeting and waiting areas. Wood inner frame with polyurethane foam padding. On wheels or floorpads. Optional: writing tablet.



struttura
legno



piedini in polipropilene o ruote



rivestimento
tessuto



pelle
ecopelle

frame
wood

polypropylene floorpads or castors

upholstery
fabric

genuine leather
faux leather

structure
bois

pieds en polypropène ou roulettes

revêtement
tissu

cuir
simili cuir

SOCIAL risponde alle esigenze di chi cerca una sedia classica nelle forme ma contemporanea nello stile. Si inserisce con facilità in spazi eleganti e minimal, portando comfort in ogni situazione. La morbida imbottitura può essere in tessuto oppure in pelle per rendere la seduta adatta ad ambienti formali.

SOCIAL

Diemme Lab / 2013

41

SOCIAL

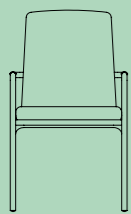
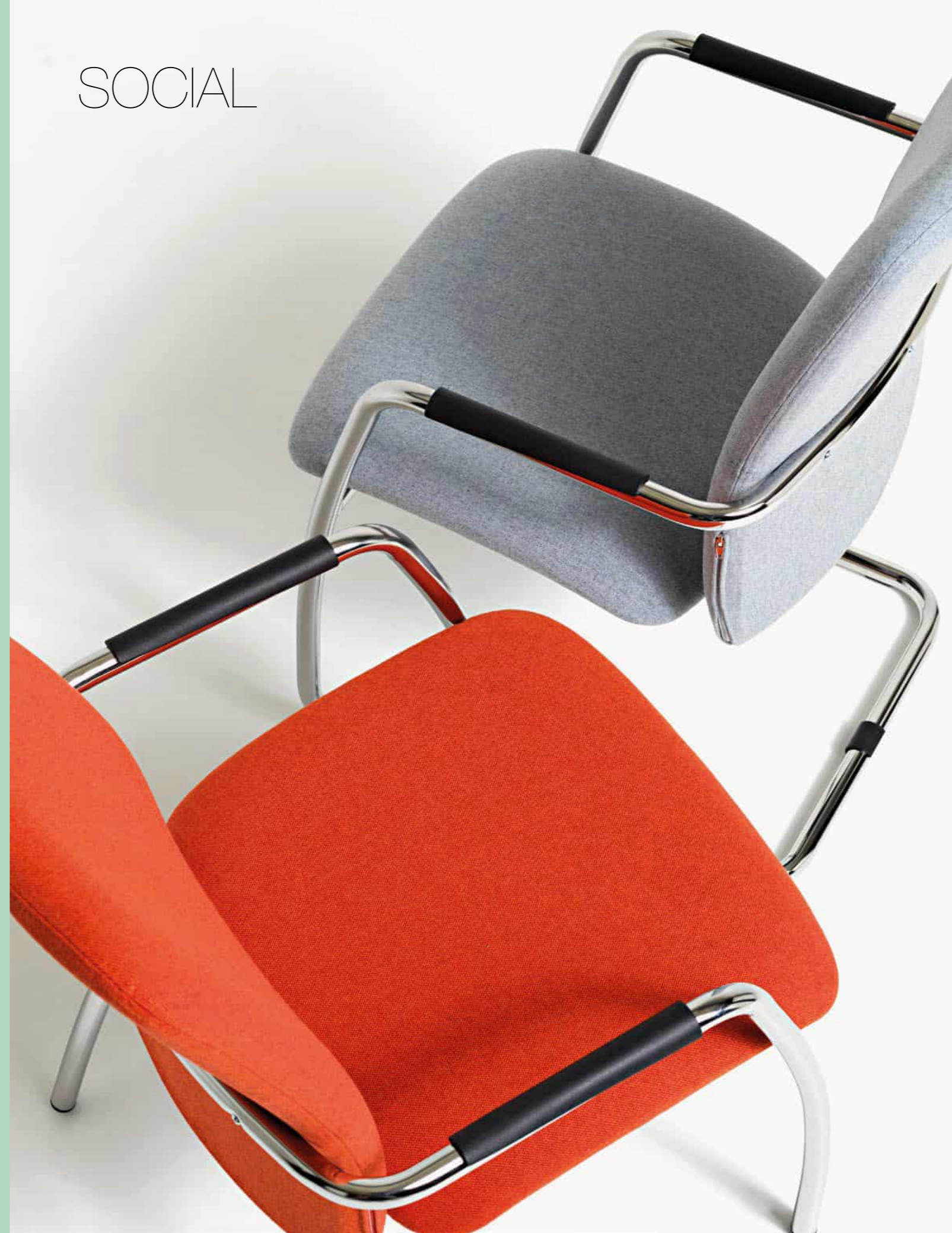

SOCIAL responds to needs of those looking for a chair with classic form, but contemporary style. It fits easily into elegant minimalist, assuring comfort in every situation. The back of the Social chair varies: its soft padding can be covered in fabric or leather to suit even more formal environments.

SOCIAL répond aux besoins de ceux qui recherchent une chaise de la forme classique, mais de style contemporain. Il s'intègre facilement dans des espaces élégants et minimal, et donne du confort dans chaque situation. Le dossier du Social est variable: le rembourrage doux de l'assise, en fait, peut être recouvert de tissu ou de cuir pour s'adapter à des environnements encore plus formels.

SOCIAL



Social community chair / Wolin 7050.36

SOCIAL

SOCIAL

Diemme Lab / 2013

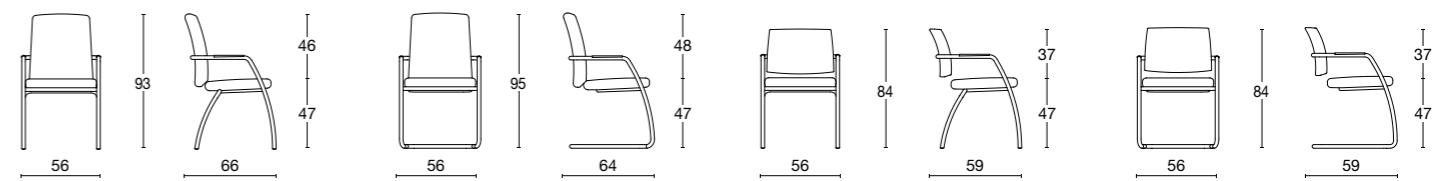

Seduta visitatore, schienale imbottito in poliuretano espanso o in rete, sedile imbottito e rivestito. Telaio slitta cromato o 4 gambe, con braccioli fissi e copribracchioli in polipropilene nero. Impilabile.

The visitor chair back is either padded in polyurethane foam or in mesh, always with an upholstered seat. Chromed frame either cantilever or on 4 legs, with fixed armrests with a black polypropylene cover. Stackable.

Siège visiteur, dossier rembourré en mousse de polyuréthane ou en resille dans la version bas dossier, assise rembourrée et revêtue. Piètement luge chromé ou 4 pieds, avec accoudoirs fixes. Empilable.



struttura
polipropilene



base cromata



rivestimento
tessuto / rete



pelle
ecopelle

frame

polypropylene

base: chromed

upholstery

fabric / mesh

genuine leather
faux leather

structure

polypropylène

base chromé

revêtement

tissu / résille

cuir
simili cuir

SLIM coniuga un design elegante a un'efficienza ingegnosa per ottenere la migliore performance dal punto di vista estetico e del comfort. Una sua caratteristica peculiare la rende estremamente pratica: fino a 40 sedie possono essere impilate le une sulle altre. Sottile, equilibrata e minimalista, Slim è adatta ad ambienti giovani e dinamici.

SLIM
Diemme Lab / 2015

49

SLIM

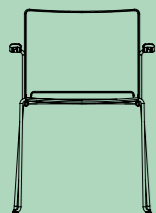

SLIM combines elegant design with ingenious efficiency to obtain the best performance from both an aesthetic and a comfort point of view. It has a distinctive feature that makes it extremely practical: Slim is stackable up to 40 pieces. Slim is well-proportioned and minimalist, making it suitable for young, dynamic environments.

SLIM allie un design élégant à une efficacité ingénieuse pour obtenir les meilleures performances à la fois d'un point de vue esthétique et de confort. Il a une caractéristique particulière qui le rend extrêmement pratique: jusqu'à 40 chaises peuvent être empilées les unes sur les autres. Mince, équilibré et minimaliste, Slim convient aux environnements jeunes et dynamiques.



Slim community chair / Nero / Bianco - Ikon 2230 / Nero / Bianco - Era CSE13

SLIM



Slim community chair / Bianco - Era CSE13

SLIM

SLIM

Diemme Lab / 2015

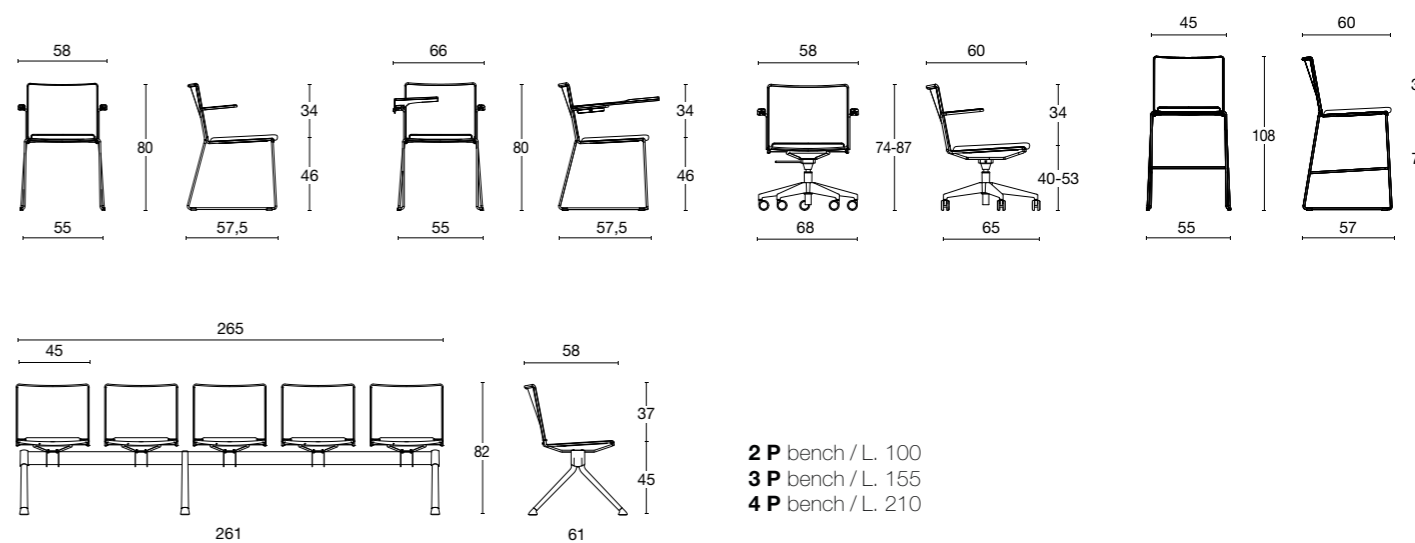

Sedia ideale per sale conferenze, come visitatore o attesa, ad alta impilabilità. Sedile e schienale in polipropilene colorato (bianco, nero, grigio e sabbia), su telaio slitta cromato o verniciato nero o bianco, con o senza braccioli. Optional: tavoletta nera in hpl, agganci per fissare la posizione in file, e carrello per portare le sedie, sedile imbottito e rivestito. Disponibile anche nella versione su gas, con base bianca, nera o in alluminio pressofuso lucido a 5 razze, su ruote gommata e auto frenanti. La versione panca a 2, 3, 4, 5 posti è perfetta per sale attesa e reception. È possibile avere anche lo sgabello, con telaio cromato o verniciato nero.

High-density stacking chair suitable for conference rooms, or for visitor and reception areas. Seat and backrest in polypropylene (white, black, grey or sand colours) on a chromed, white or black sled base; available with or without armrests. Optional: HPL writing tablet, link mechanisms, chair trolley, padded seats and/or backs. Available also with gaslift, on a black, white or polished aluminium 5-spur base on rubber castors. The two, three, four and five-seater beam units are ideal for reception areas. Beam seating is available on 2/3/4/5 seater is perfect for reception areas. A barstool is available on a chromed or black lacquered base.

Chaise idéale pour les salles de conférence, en tant que visiteur ou en attente, haute empilabilité. Assise et dossier en polypropylène coloré (blanc, noir, gris et sable), sur piètement luge chromé ou peint en noir ou blanc, avec ou sans accoudoirs. En option: tablette hpl noire, crochets pour fixer le chaises, chariot, assise et dossier rembourré. Disponible en version gaz, base blanc, noir, ou aluminium à 5 rayons, sur roulettes caoutchoutées et auto-freinant. La version poutre avec 2, 3, 4, 5 places est parfaite pour les salles d'attente et les zones de réception. Il est également possible d'avoir le tabouret, avec piètement chromé ou noir.



struttura
polipropilene



base cromata / verniciata bianca / verniciata nera / polipropilene bianca / polipropilene nera / alluminio lucido



rivestimento
tessuto



pelle
ecopelle

frame
polypropylene

base: chromed / white lacquered / black lacquered / black polypropylene / polished aluminium

upholstery
fabric

genuine leather
faux leather

structure
polypropylène

base aluminium / blanche / noire ou chromée / polypropylène noir

revêtement
tissu

cuir
simili cuir



Pratica e insolita, **SUNNY NEW** è l'ideale per chi cerca una seduta funzionale senza rinunciare a una certa originalità estetica. È morbida nella seduta e versatile nella struttura. Può essere dotata di tavoletta e dispositivo di aggancio per sale conferenza, ed è disponibile anche in versione panca. Lo slittamento del doppio schienale e la curvatura delle gambe donano a Sunny New leggerezza e dinamicità.

SUNNY NEW 59

Diemme Lab / 2014

SUNNY NEW

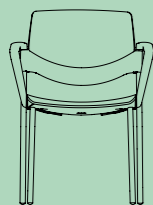

Practical and unusual, SUNNY NEW is ideal for those looking for a functional chair with an original look. With its soft seat and versatile frame, it can be fitted with linking mechanisms and a writing tablet for conference rooms, and is also available on beam. The combination of the double backrest and the splay of the four legs give Sunny New lightness and dynamism.

Pratique et inhabituel, SUNNY NEW est idéal pour ceux qui recherchent un siège fonctionnel mais qui ne veulent pas renoncer à une certaine originalité esthétique. Doux et polyvalent dans la structure, il peut être équipé de crochets et d'une tablette écrite pour les salles de conférence, et il est également disponible en version poutre. Le dossier particulier et l'arche des quatre pieds confèrent légèreté et dynamisme au Sunny New.



SUNNY NEW

SUNNY NEW

Diemme Lab / 2014

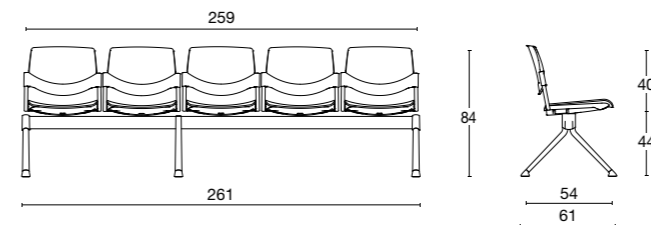
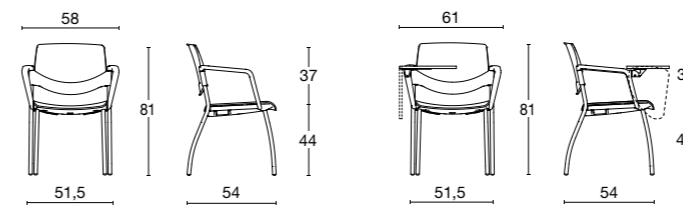

2 P bench / L. 103
3 P bench / L. 155
4 P bench / L. 207

Sedia per la collettività, sedile e schienale in polipropilene bianco o nero, disponibile anche con schienale e sedile rivestiti, o solo sedile. Telaio 4 gambe verniciato nero o cromato. Braccioli neri o bianchi, possibilità di tavoletta scrittoio e agganci fissi. Disponibile anche su panca 2/3/4/5 posti.

Community chair, with seat and backrest in black or white polypropylene, or with seat and/or back upholstered. Chromed or black-lacquered four-legged frame. Fixed black or white armrests, optional writing tablet and linking mechanisms. Two, three, four and five-seater beam units available.

Chaise de collectivité, assise et dossier en blanc ou polypropylène noir, également disponible avec dossier et assise rembourrés, ou revêtement seulement sur l'assise. Piètement 4 pieds peint en noir ou chromé. Accoudoirs noirs ou blancs, possibilité de tablette et crochets. Aussi disponible sur poutre 2/3/4/5 places.

struttura
polipropilene

base cromata / verniciata nera

rivestimento
tessuto

pelle
ecopelle

frame
polypropylene

base: chromed / black lacquered

upholstery
fabric

genuine leather
faux leather

structure
polypropylène

base noire ou chromée

revêtement
tissu

cuir
simili cuir



Con la sua linea semplice
e confortevole, **NEW BONN**
è l'emblema della seduta
per zone di ritrovo e di accoglienza.
Praticità ed essenzialità
si coniugano in una serie
di poltroncine, singole o multiple,
ideali per ambienti dinamici e moderni.
New Bonn è versatile, leggera
e piacevole alla vista.

NEW BONN

Diemme Lab / 2020

67

NEW BONN

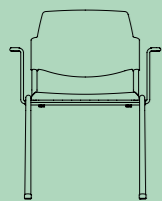
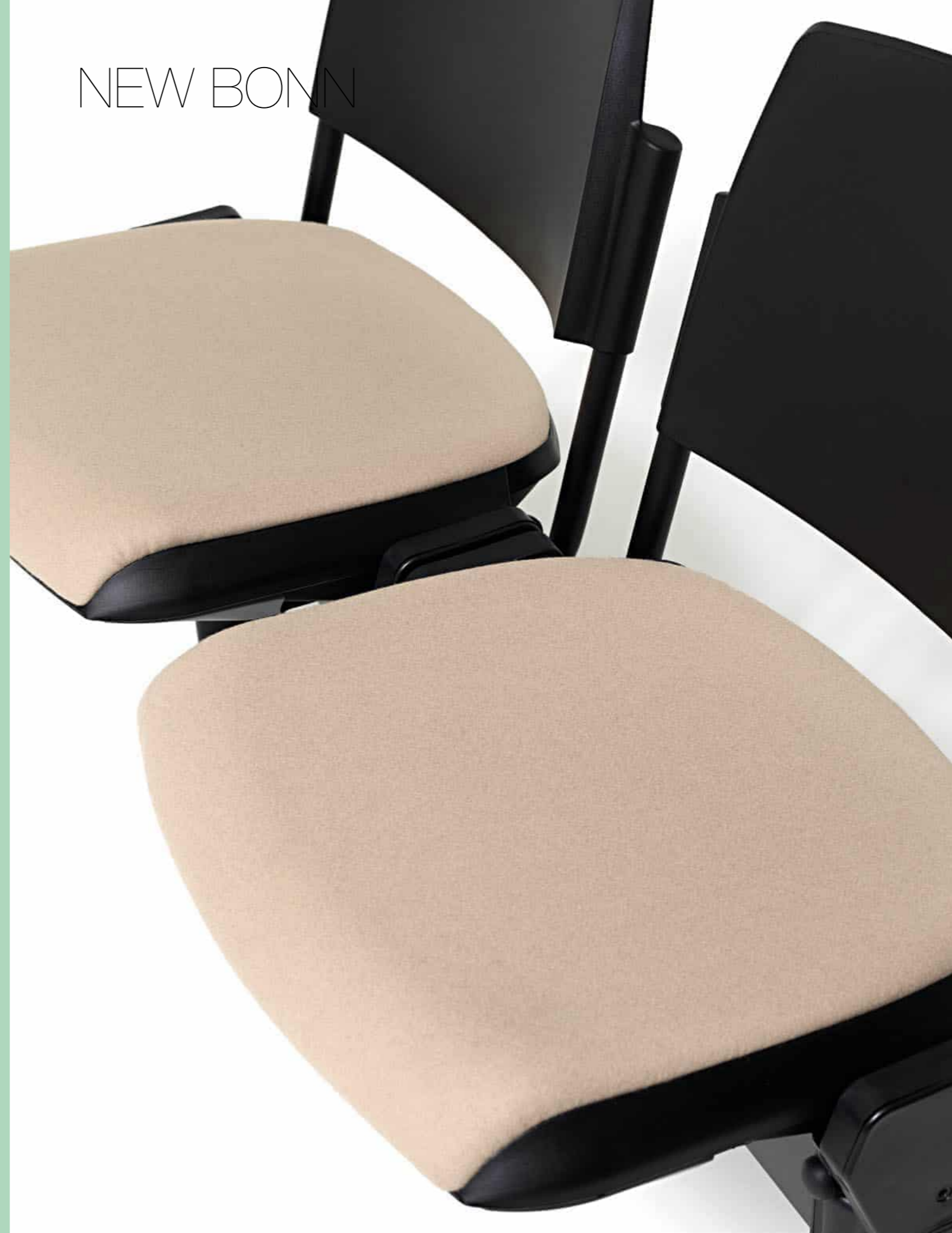

With its clean and comfortable lines, NEW BONN is flagship chair for meeting and reception areas. Practicality and essentiality are its key features, and these are combined in a series of single or multiple armchairs ideal for dynamic, modern environments. In its simplicity, New Bonn is versatile, light and looks great; it offers sobriety and comfort at the same time.

Avec sa ligne épurée et confortable, NEW BONN est l'emblème du siège des espaces de réunion et d'accueil. La praticité et l'essentialité sont ses points cardinaux, et sont combinés dans une série de chaises multiples idéaux pour les environnements dynamiques et modernes. Dans sa simplicité, New Bonn est polyvalent, léger et agréable à l'œil; il offre à la fois sobriété et confort.



New Bonn community chair / Blazer CUZ08 / Nero - Blazer CUZ47 / Blazer CUZ30 /
Mesh 8043 - Blazer CUZ28 / Nero / Blazer CUZ47

NEW BONN



New Bonn community chair / Blazer CUZ08

NEW BONN



New Bonn community chair / Mesh 8043 - Blazer CUZ28

NEW BONN

Diemme Lab / 2020



New Bonn community chair / Antracite / Nero / Bianco / Rosso / Blu

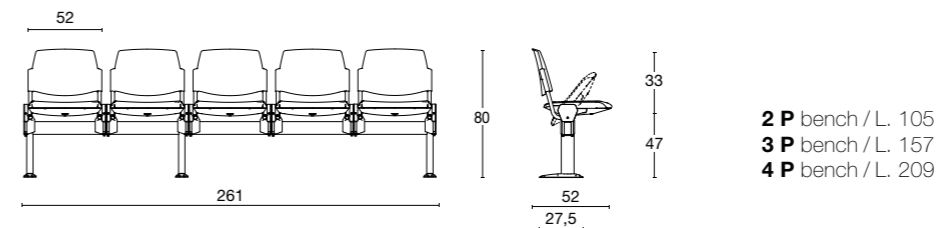
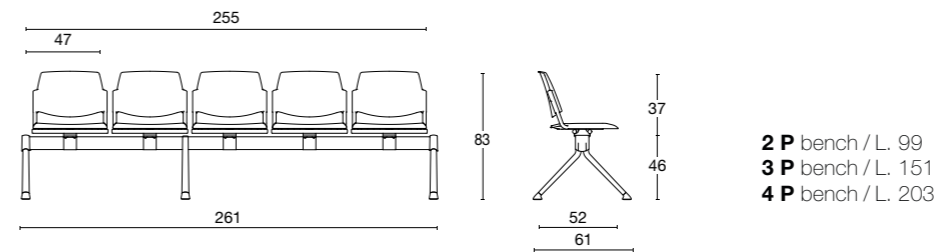
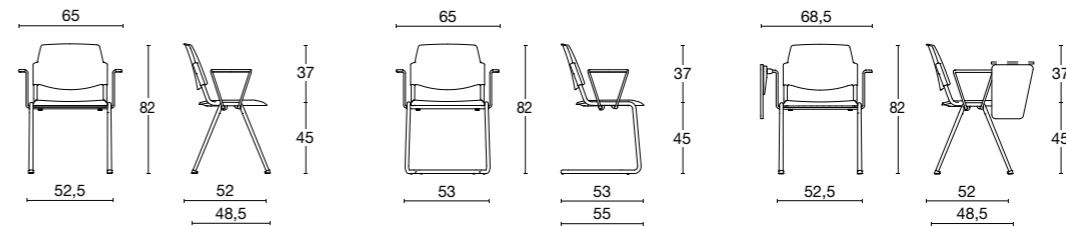

2 P bench / L. 99
3 P bench / L. 151
4 P bench / L. 203

2 P bench / L. 105
3 P bench / L. 157
4 P bench / L. 209

Sedia impilabile multiuso con o senza braccioli, corredata da vari e funzionali accessori (tavoletta per scrittura, agganci, carrello porta sedie). Seduta e schienale possono essere imbottiti in poliuretano espanso, o in polipropilene in diversi colori o ancora con schienale in rete. Il telaio 4 gambe o slitta e i braccioli possono essere verniciati nero o cromati. Disponibile anche in versione panca da 2/3/4/5 posti fissa o con sedile ribaltabile e fissaggio a terra.

Multifunctional stacking side or armchair, stackable available with various options: writing tablet, document tray, linking mechanisms, trolley. Seat and back in a choice of polypropylene colours, upholstered. Mesh backrest also available. The four-legged or sled frames and the armrests can be chromed or lacquered black. Two, three, four and five-seater beam units available, optionally with tip-up seat and floor fixing.

Chaise empilable polyvalente avec ou sans accoudoirs, équipée des accessoires fonctionnels (tablette écriteur, crochets, chariot). L'assise et le dossier peuvent être rembourrés en polyuréthane et revêtues, ou ils sont disponibles en polypropylène en différentes couleurs ou avec dossier en résille. Les 4 pieds ou piètement luge et les accoudoirs peuvent être peints en noir ou chromé. Disponible aussi en version 2/3/4/5 fixe ou poutre avec assise pliable et fixation au sol.



struttura
 polipropilene



base cromata / verniciata nera



rivestimento
 tessuto / rete



pelle
 ecopelle

frame

polypropylene

base: chromed / black lacquered

upholstery

fabric / mesh

genuine leather
 faux leather

structure

polypropylène

base noire ou chromée

revêtement

tissu / résille

cuir
 simili cuir

La forma sinuosa di **NO FRILL**
è progettata per accompagnare
dolcemente la curva della schiena.
Il telaio in metallo può essere verniciato
bianco, antracite, oppure cromato.
Con l'aggiunta di un sedile imbottito
aumenta l'ampia scelta
di combinazioni colore.
No Frill è un'aggiunta fresca
e versatile per ogni stile di arredo.

NO FRILL

Diemme Lab / 2017

79

NO FRILL

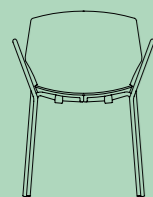

The captivating lines of NO FRILL are designed gently to accompany the curve of the anthracite. The metal frame can be chromed or lacquered black or white. No Frill is optionally available with an upholstered seat, thus greatly increasing the choice of colourways, effortlessly to match any furnishing style.

La ligne captivante de NO FRILL est conçue pour accompagner en douceur la courbure du dossier. Le piètement en métal peut être peint en blanc, anthracite ou chromé. No Frill offre la possibilité d'ajouter un coussin d'assise rembourré et couvert, augmentant ainsi la largeur choix de combinaisons de couleurs disponibles qui s'adaptent sans effort à n'importe quel style d'ameublement.

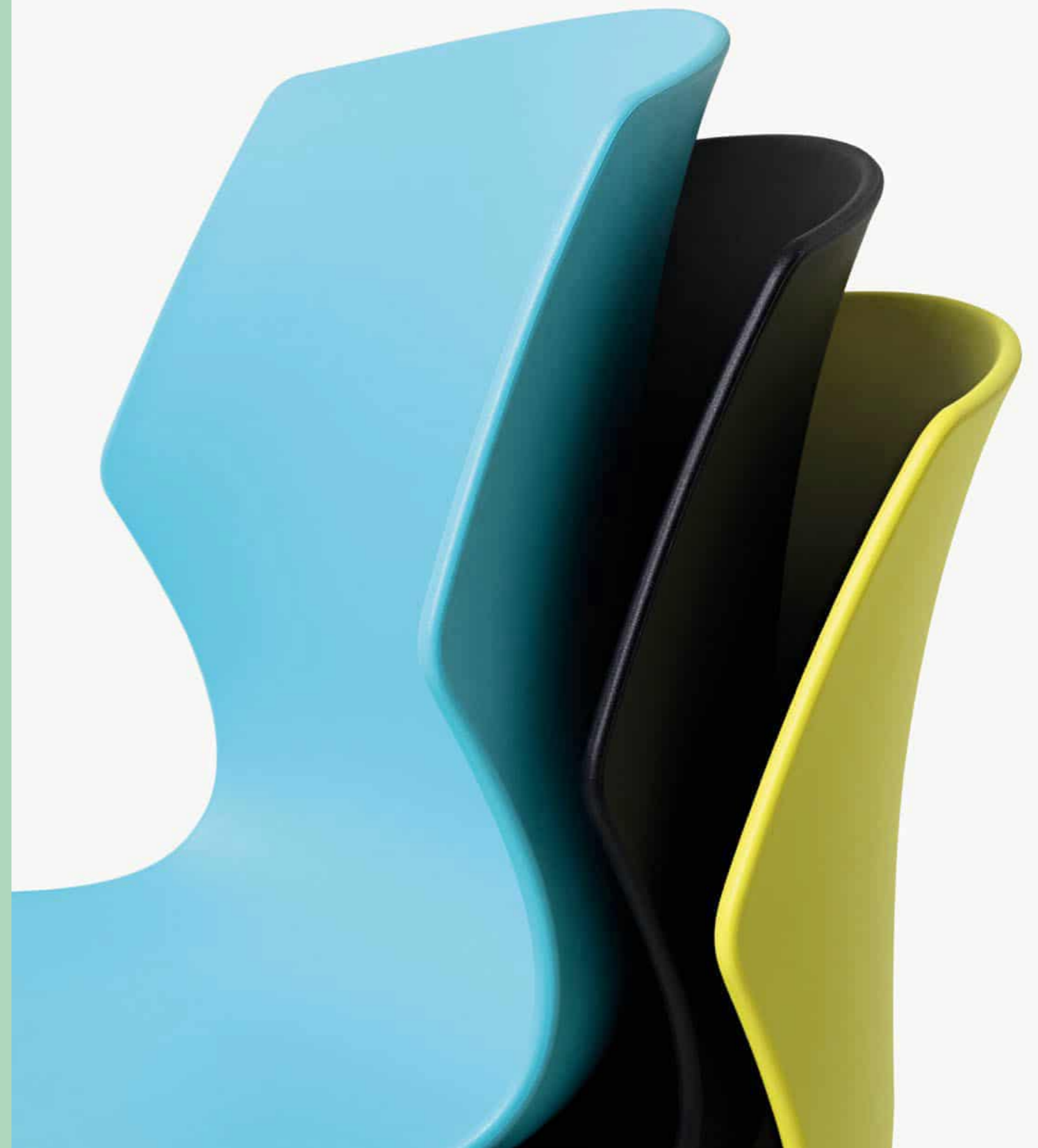

NO FRILL



No Frill community chair / Giallo Cedro - Ikon 130 / Azzurro / Sabbia / Antracite / Bianco

NO FRILL



No Frill community chair / Giallo Cedro - Ikon 130

NO FRILL

Diemme Lab / 2017



No Frill community chair / Antracite / Azzurro

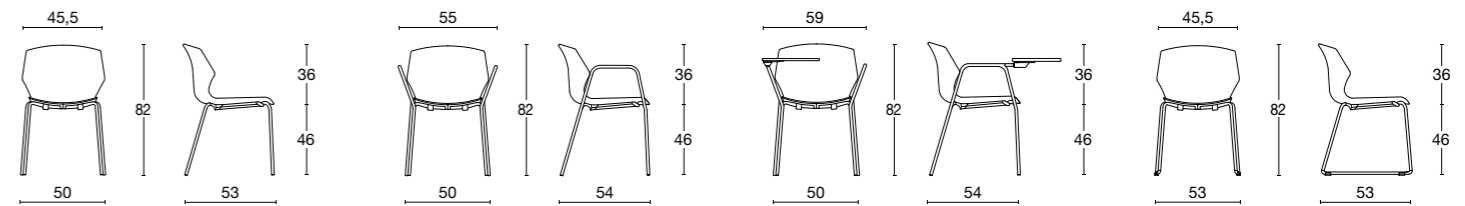

Monoscocca in polipropilene disponibile in 5 varianti di colore: azzurro, giallo, beige, bianco e antracite. Telaio in metallo verniciato bianco, antracite oppure cromato, disponibile nella versione base slitta o a 4 gambe con o senza braccioli fissi. Optional: sedile imbottito e rivestito e tavoletta scrittoio. Impilabile fino a 6 pezzi.

Single shell in polypropylene available in 5 different colours: light blue, yellow, sand, white and dark grey. Four-legged or sled frames, available chromed or lacquered white or dark grey. With or without arms. Optional: upholstered seat and writing tablet. Stackable up to 6 pieces.

Monocoque en polypropylène disponible en 5 variantes de couleur: bleu clair, jaune, beige, blanc et anthracite. Piètement en métal peint en blanc, anthracite ou chromé, disponible en version luge ou en version 4 pieds avec ou sans accoudoirs fixes. En option: assise rembourrée et tablette écriteiro. Empilable jusqu'à 6 pièces.



struttura
polipropilene



base cromata / verniciata bianca / verniciata antracite



rivestimento
tessuto



pelle
ecopelle

frame

polypropylene

base: chromed / white lacquered / dark grey lacquered

upholstery

fabric

genuine leather
faux leather

structure

polypropylène

base anthracite / blanche ou chromée

revêtement

tissu

cuir
simili cuir

NUKE, allegra e confortevole,
è realizzata in materiale 100% riciclabile.
Resistente ai raggi UV e agli agenti
atmosferici, è la seduta ideale
per gli ambienti esterni.
Pensata in quattro varianti colore:
azzurro, giallo, arancione e bianco.
Originale per la sua composizione fisica
e per la sua giocosità, è unica
nel suo genere.

NUKE

Diemme Lab / 2017

89

NUKE

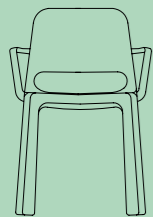

NUKE, cheerful and comfortable, is made of 100% recyclable material. Resistant to UV rays, it is the ideal chair for outdoor use because it withstands all weather conditions. Nuke comes in four colours: blue, yellow, orange and white. It is an original chair both for its physical composition as well as for its playfulness, a sheer one-off.

NUKE, joyeux et confortable, est fait de matière 100% recyclable. Résistant aux rayons UV, il est le siège idéal pour les environnements extérieurs car il parvient à contraster agents atmosphériques. Nuke est conçu en quatre variantes de couleur: bleu, jaune, orange et blanc. C'est un siège original à la fois pour sa composition physique et pour son aspect ludique, unique en son genre.

NUKE



Nuke community chair / Giallo Cedro / Bianco / Arancione / Azzurro



Nuke community chair / Arancione / Giallo Cedro / Bianco / Azzurro

NUKE

NUKE

Diemme Lab / 2017

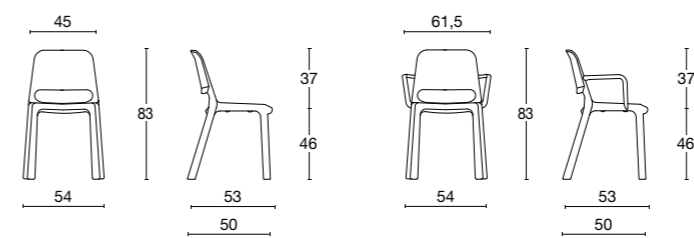

Sedia polivalente, totalmente in polipropilene, 100% riciclabile e resistente ai raggi UV, ideale quindi per un utilizzo anche in aree esterne. Struttura unica a 4 gambe con o senza braccioli fissi. Disponibile in 4 varianti di colore: azzurro, giallo, arancione e bianco. Impilabile fino a 6 pezzi.

Multi-purpose polypropylene chair, 100% recyclable and UV-resistant, ideal for outdoor use. Four-legged frame, with or without arms. Available in 4 different colours: light blue, yellow, orange and white. Stackable up to 6 pieces.

Chaise polyvalente, totalement en polypropylène, 100% recyclable et résistant aux UV, donc idéal pour une utilisation même dans les zones extérieures. Structure unique en polypropylène à 4 pieds avec ou sans accoudoirs fixes. Disponible en 4 couleurs: bleu, jaune, orange et blanc. Empilable jusqu'à 6 pièces.



struttura
polipropilene

frame
polypropylene

structure
polypropylène

“Il desiderio di leggerezza e comfort all’interno di spazi sempre più complessi è la conseguenza del tempo in cui viviamo, sempre in continua e crescente accelerazione. La qualità dello spazio influisce su ogni cosa: per questo motivo materiali e forme devono unirsi per offrire autenticità, affetto e ispirazione.”

Visitatore

Visitor | Chaises visiteur



CLOP

99

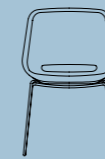

CLEA

109



CLEA PLUS

119

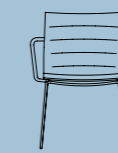

MISS

127



EON

139

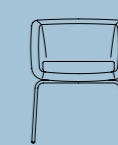

VANITY

153



MARGARITA

163

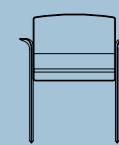

MISTER

171

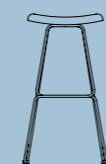

CHAT

177



PRINCE

183

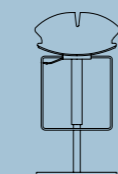

RED HOT

189

"The desire for lightness and comfort within ever more complex spaces results from to the moment we are currently living, in continuous and increasing acceleration. The quality of the spaces in which we find ourselves affects everything, we take care that, within them, uniting materials and shapes make us feel good and offer authenticity, affection and inspiration."

"Le désir de légèreté du confort dans des espaces de plus en plus complexes est dû au moment actuel que nous vivons, continuellement en accélération. La qualité de l'espace dans lequel nous trouvons affecte tout, nous voulons que les matériaux et les formes nous fassent se sentir bien et offrent de l'authenticité, affection et inspiration."

Nella versione visitatore,
CLOP accompagna facilmente
altri elementi d'arredo grazie
alle sue molteplici possibilità
di personalizzazione.
Disegnata da DorigoDesign,
CLOP si contraddistingue per
le linee leggere e avvolgenti.
Il suo design vintage si combina
a un'attitudine contemporanea
al servizio della fruibilità
e dell'ergonomia.

CLOP
DorigoDesign / 2018

99

CLOP

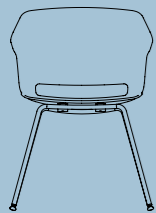

In its visitor version, CLOP easily accompanies other furnishings thanks to its rich possibilities of personalisation. Designed by DorigoDesign, Clop stands out for its clean lines and for its enveloping shell back. Its vintage design combines with a contemporary attitude to make Clop an ergonomic choice.

Dans la version visiteur, CLOP accompagne facilement d'autres meubles grâce à ses riches possibilités de personnalisation. Conçu par DorigoDesign, Clop se démarque pour la légèreté de ses lignes et par le sentiment enveloppant donné par la coque. Son design vintage épouse une attitude contemporaine qui met Clop au service de l'ergonomie.



CLOP



Clop visitor chair / Wolin 7050.38

CLOP



Clop visitor chair / Wolin 7050.22



CLOP

DorigoDesign / 2018



Clop visitor stool / Jet 9804 / Bianco

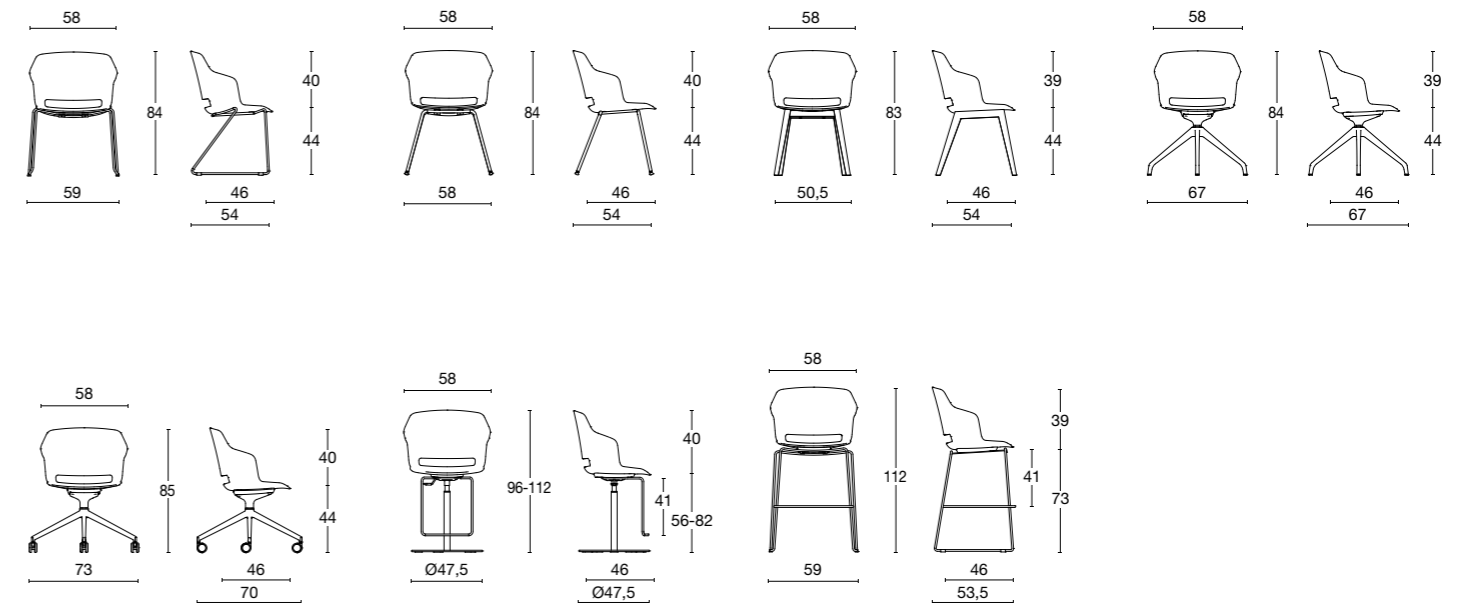

Poltroncina dal design innovativo e dalle linee leggere, la scocca è in polipropilene disponibile in diversi colori. Può essere completamente rivestita, oppure con solo il cuscinetto sedile optional. La gamma comprende la versione fissa su telaio 4 gambe o slitta, bianco, nero o cromato, o su basamento 4 gambe in legno di frassino. La versione girevole su basamento in polipropilene piramidale, bianco o nero, su basamento piramidale in alluminio lucido, nero o bianco su ruote. È disponibile anche in versione con meccanismo (vedere sezione operative) o su panca o con tavoletta scrittoio (vedere sezione collettività).

An armchair with an innovative design and clean lines, the polypropylene shell is available in different colours. It can be completely upholstered, or fitted with just a seat cushion. The range includes the fixed version on a black, white or chromed four-legged or sled frame, or on 4 legs in ashwood. The swivel version comes: on pyramid base in a choice of base finishes; black or white polypropylene; or in black, white or polished aluminum on castors. It is also available in a stool version for breakout areas, with a fixed chromed base, or a round base with gas lift. The family also includes the version with mechanism (see task seating section), or on beam, or with writing tablet (see contract section).

Fauteuil au design innovant et aux lignes légères, la coque est en polypropylène disponible en différentes couleurs. Il peut être entièrement recouvert, ou avec seulement le coussin d'assise en option. La gamme comprend la version fixe sur un piètement à 4 pieds en bois de frêne. La version pivotante pyramidale en polypropylène, blanc ou noir, sur base pyramidale en aluminium poli, noir ou blanc sur roulettes. Il est également disponible en version tabouret pour les zones break, avec une base fixe chromée ou une base ronde avec vérin à gaz. La famille comprend également le modèle avec mécanisme (voir section sièges de bureau) ou sur poutre ou avec tablette écriteire (voir section chaises collectivité).



struttura
polipropilene



base cromata / verniciata nera / verniciata bianco / alluminio lucido / polipropilene nero / polipropilene bianco



rivestimento
tessuto



pelle / cuoio
ecopelle

frame

polypropylene

base: chromed / black lacquered / white lacquered / polished aluminum / black polypropylene / white polypropylene

upholstery

fabric

genuine leather / hide
faux leather

structure

polypropylène

piètement chromé / peint en noir / peint en blanc / aluminium poli / polypropylène noir / polypropylène blanc

revêtement

tissu

cuir / sellier
simili cuir

CLEA è una seduta dal profilo morbido e sinuoso. La dolcezza delle sue forme è ripresa anche nei braccioli cromati opzionali, che scorrono lungo la seduta in un tratto curvilineo ininterrotto. Armoniosa ed elegante, è disponibile anche nella versione **CLEA PLUS**, una poltroncina che si distingue per le sue forme tondeggianti e i braccioli incorporati.

CLEA

Diemme Lab / 2017

111

CLEA

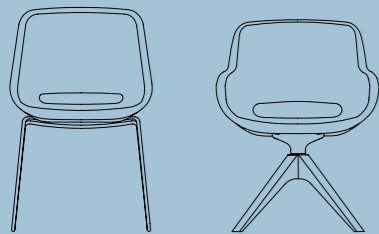

CLEA is a chair with a soft and sinewy profile. The sweetness of its forms follows through into the optional chromed armrests, the curves of which flow uninterrupted around the chair. Harmonious and elegant, Clea is also available in the version CLEA PLUS, an armchair that it is characterised by its rounded shape thanks to its distinctive armrests.

CLEA est une chaise avec un profil doux et sinueux. La douceur de ses formes est également reprise dans les accoudoirs chromés en option, qui coulent tout au long de l'assise curviligne. Harmonieux et élégant, Clea est également disponible dans la version CLEA PLUS, fauteuil qui se caractérise par sa forme avec accoudoirs arrondis qui la distinguent.



Clea visitor chair / Wolin 7050.22 - 7050.36 - 7050.19 - 7050.31

CLEA

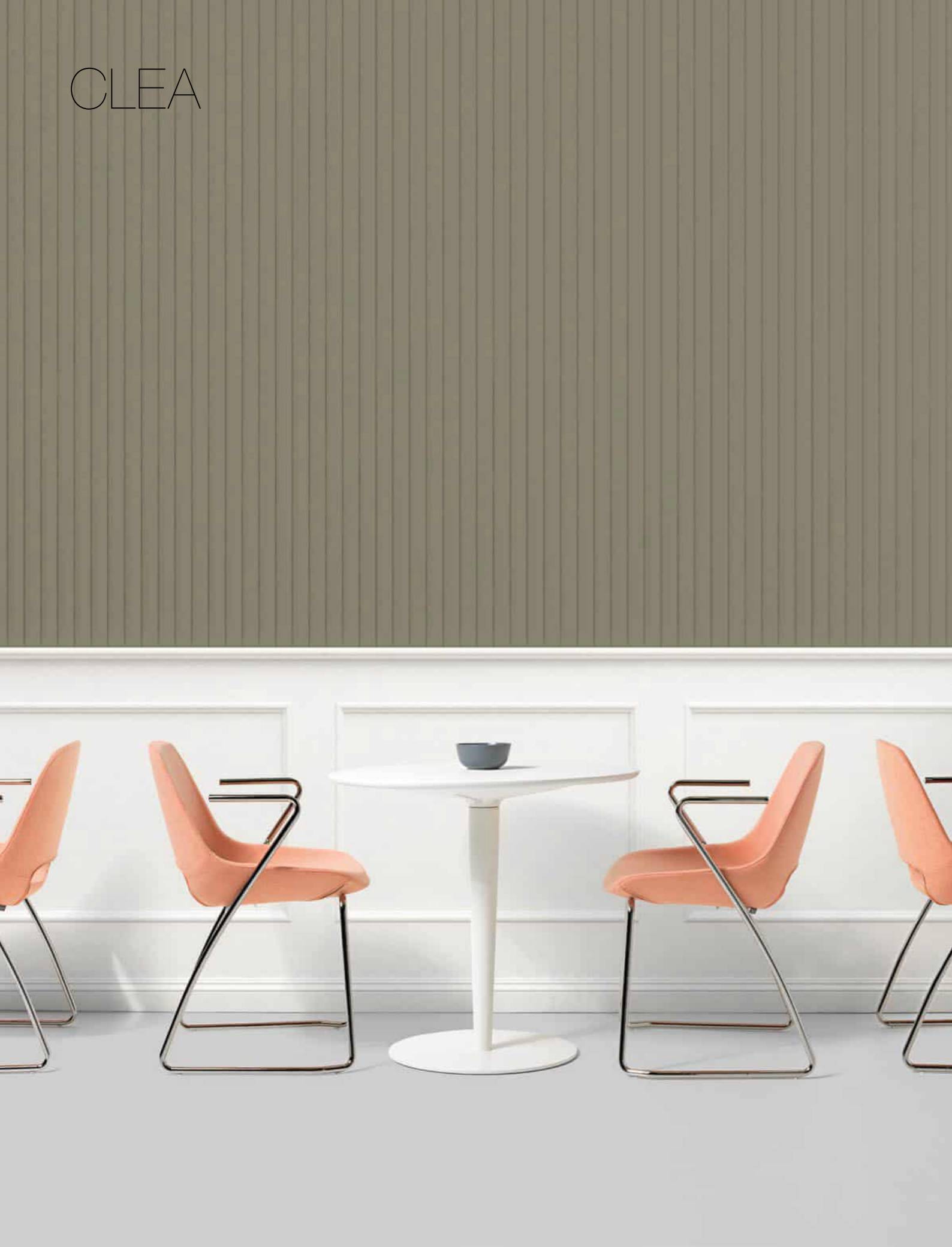

Clea visitor chair / Wolin 7050.31

CLEA

Diemme Lab / 2017



Clea visitor chair / Wolin 7050.19

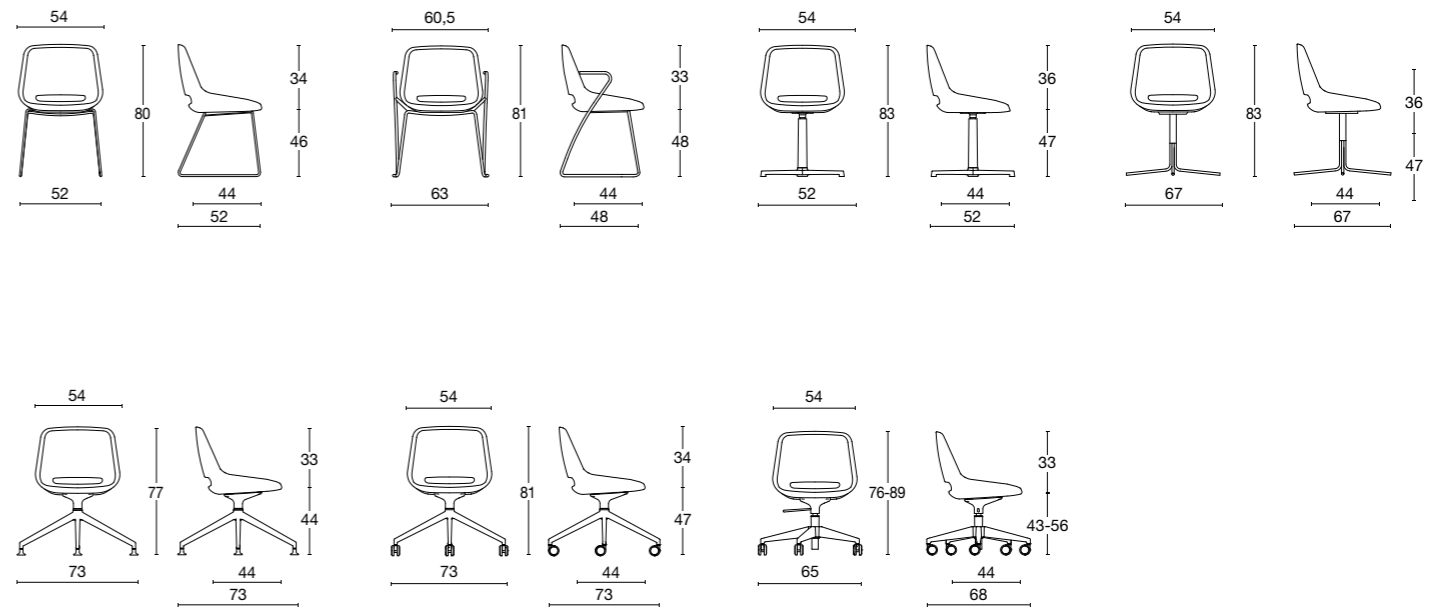

Seduta dalla linea sinuosa, con struttura interna in acciaio e imbottitura in poliuretano schiumato a freddo. Disponibile su vari basamenti: base girevole 5 razze in alluminio con alzata gas su ruote gommate, base 4 lame in alluminio con meccanismo di ritorno automatico, base girevole a 4 razze in tubolare di acciaio, base slitta cromata o base piramidale in alluminio verniciata bianca o nera.

A curvy shell with inner steel structure and padding in cold polyurethane foam. Available on various bases: 5-spur aluminum with swivel, gas lift and rubber wheels; 4 aluminum blades with automatic return mechanism; 4 tubular steel spokes with swivel; chromed sled; black or white lacquered pyramid.

Siège sinueux, avec structure interne en acier et rembourrage en polyuréthane moulée à froid. Disponible sur différentes bases: base aluminium à 5 branches pivotant avec vérin à gaz sur roulettes, base 4 lames en aluminium avec mécanisme de retour automatique, base pivotante à 4 rayons en tube d'acier, piètement luge chromée ou base pyramidale en aluminium peint en blanc ou noir.



struttura
acciaio



base cromata / alluminio lucido / verniciata nero / verniciata bianca



rivestimento
tessuto



pelle
ecopelle

frame
steel

base: chromed / polished aluminum / black lacquered / white lacquered

upholstery
fabric

genuine leather
faux leather

structure
acier

piètement chromé / aluminium poli / peint en noir / peint en blanc

revêtement
tissu

cuir
simili cuir

CLEA PLUS





CLEA PLUS



Clea Plus visitor chair / Blazer CUZ31

CLEA PLUS

CLEA PLUS

Diemme Lab / 2017

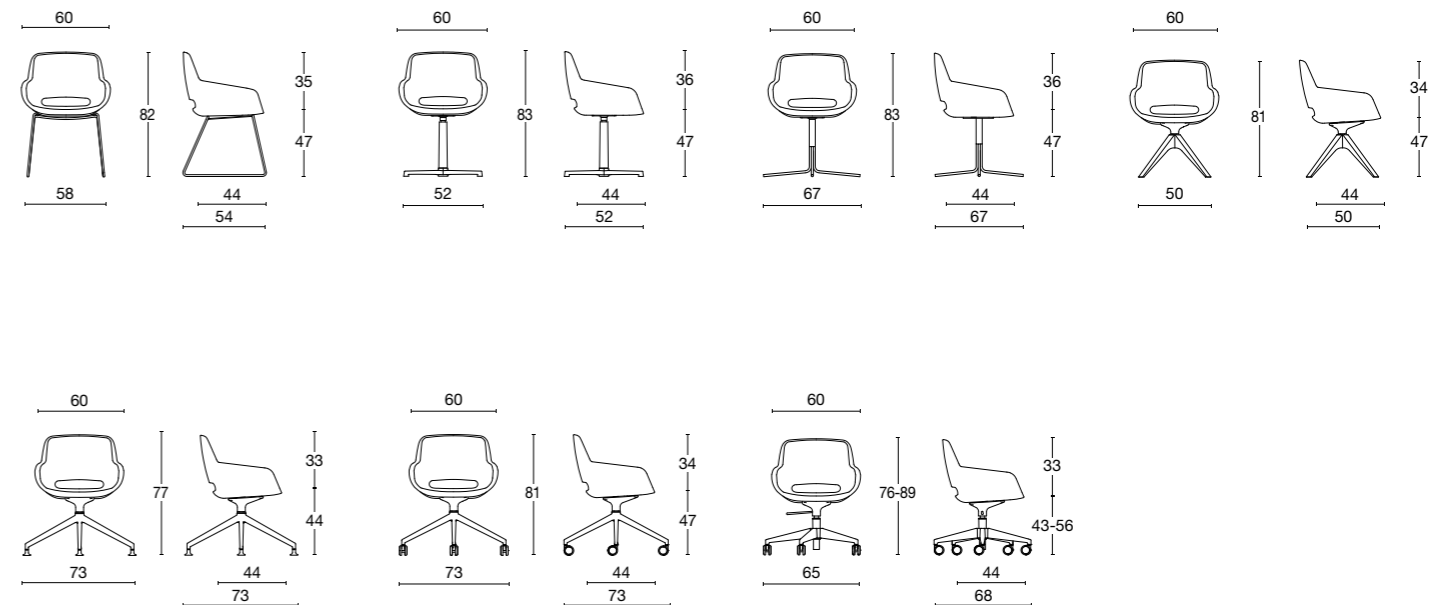

Poltroncina dalla linea sinuosa, con struttura interna in acciaio e imbottitura in poliuretano schiumato a freddo. Disponibile su vari basamenti: base girevole 5 razze in acciaio con alzata gas su ruote gommata, base 4 lame in alluminio con meccanismo di ritorno automatico, base girevole a 4 razze in tubolare di alluminio, base slitta cromata o base piramidale in alluminio verniciata bianca o nera o ancora su telaio in legno 4 gambe, girevole.

An armchair with sinewy lines and an inner steel structure and padding in cold polyurethane foam. Available on various bases: 5-spur aluminum with swivel, gas lift and rubber wheels; 4 aluminum blades with automatic return mechanism; 4 tubular steel spokes with swivel; chromed sled; black or white lacquered pyramid; wooden four-legged pyramid frame with swivel.

Fauteuil avec une ligne sinueuse, avec structure en acier interne et rembourrage en polyuréthane moulée à froid. Disponible sur divers bases: base pivotante 5 rayons en aluminium avec vérin à gaz sur roulettes base en aluminium à 4 lames avec mécanisme de retour base pivotante automatique à 4 branches en aluminium tubulaire, base luge base chromée ou pyramidale en aluminium peint en blanc ou noir ou toujours sur châssis en bois 4 pieds, pivotant.



struttura
acciaio



base cromata / alluminio lucido / verniciata nero / verniciata bianca / legno di frassino



rivestimento
tessuto



pelle
ecopelle

frame
steel

base: chromed / polished aluminum / black lacquered / white lacquered / ashwood

upholstery
fabric

genuine leather
faux leather

structure
acier

piètement chromé / aluminium poli / peint en noir / peint en blanc / bois de frêne

revêtement
tissu

cuir
simili cuir

MISS è caratterizzata da linee dinamiche e raffinate. Moderna e minimalista, ha una seduta ampia e uno schienale sinuoso per supportare la postura della persona e favorire il comfort. Il bracciolo accessorio attraversa lo schienale con un segno sottile e netto.

MISS
Diemme Lab / 2007

129

MISS

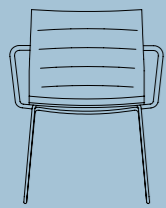

MISS is characterised by its dynamic and refined lines. Modern and minimalist, it has a generous seat and a slinky backrest that supports the user's posture and ensures comfort. Its armrests sweep decisively and finely around the backrest.

MISS se caractérise par des lignes dynamiques et raffinées. Moderne et minimaliste, Miss a une grande assise et un dossier sinueux qui soutient la posture de la personne et favorise le confort. L'accoudoir en accessoire traverse le dos avec un signe subtil et clair.



Miss visitor chair / Blazer CUZ08 / Planet 1304.126 / Blazer CUZ28 - Planet 6.101 /
Blazer CUZ30 - Planet 1984.125 / Planet 1304.126

MISS



Miss visitor chair / Planet 6.101

MISS



Miss visitor chair / Blazer CUZ30 - Planet 1984.125



MISS

Diemme Lab / 2007



Miss visitor stool / Blazer CUZ28 - Planet 6.101

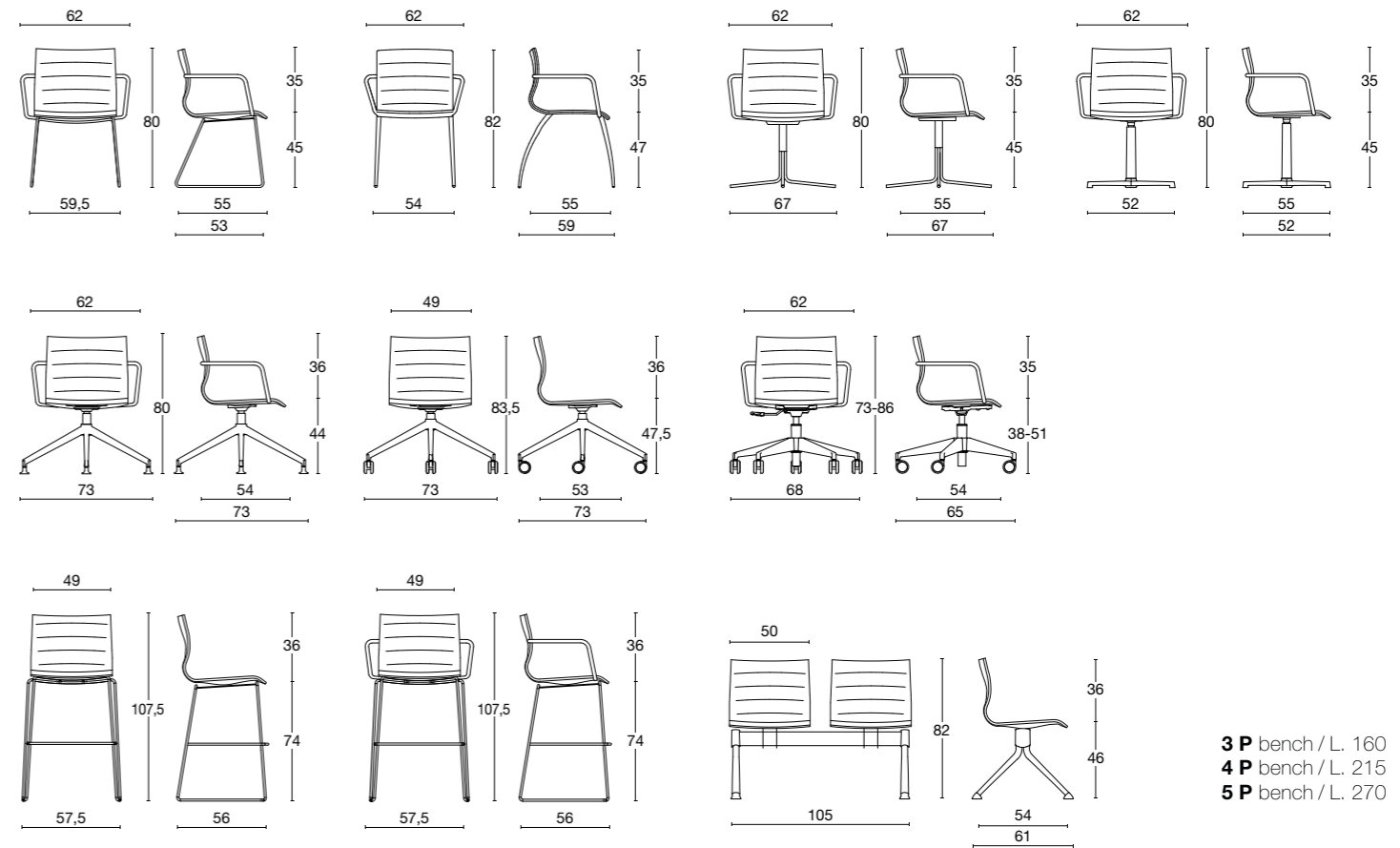





3 P bench / L. 160
4 P bench / L. 215
5 P bench / L. 270

Poltroncina versatile ideale per il contract e l'ufficio. La monoscocca è in multistrato di faggio, imbottita e rivestita. La base può essere: girevole su ruote con elevazione a gas; meccanismo knee-tilt; su telaio girevole tubolare; su 4 lame in alluminio ad altezza fissa con ritorno automatico in posizione, o ancora su telaio a 4 gambe cromato, su base slitta; su base 4 razze piramidale in alluminio verniciato bianco o nero. Con o senza braccioli in tubolare cromato, verniciati neri o bianchi. Disponibile lo sgabello fisso cromato o su panca da 2/3/4/5 posti.

Armchair with exceptional versatility, ideal for home, contract and office. The single shell is in beech plywood, padded and upholstered. The base can be: with swivel, gas lift and castors; with knee-tilt mechanism; on tubular swivel frame; on 4 aluminum blades at fixed height with swivel and return mechanism; four chromed legs; sled base; black or white painted four-spur aluminum pyramid. Optionally with black or white lacquered or chromed tubular armrests. Also available as a barstool on chromed sled; or as two, three, four or five-seater beam units.

Fauteuil polyvalent idéal pour la maison, le contract et le bureau. Le mono-coque est en contreplaqué de hêtre, rembourré et recouvert. La base peut être: pivotante sur roulettes avec vérin à gaz; mécanisme oscillant; sur piètement tubulaire pivotant; sur 4 lames en aluminium hauteur fixe avec retour automatique en position, ou même sur 4 pieds chromé, sur piètement luge; sur piètement 4 branches en aluminium, peint blanc ou noir. Avec ou sans accoudoirs tubulaires chromés, ou peint en noir ou blanc. Aussi disponible le tabouret fixe chromé ou poutre 2/3/4/5 places.

-  **struttura**
multistrato di faggio
-  base cromata / alluminio lucido / verniciata nera / verniciata bianca
-  **rivestimento**
tessuto
-  pelle
ecopelle

- frame**
beech plywood
- base: chromed / polished aluminum / black lacquered / white lacquered
- upholstery**
fabric
- genuine leather
faux leather

- structure**
contreplaqué de hêtre
- base chromé / aluminium poli / peint en noir / peinte en blanc
- revêtement**
tissu
- cuir
simili cuir

Disegnato da Plus Design,
EON è un sistema di sedute
singolare e versatile.

Con la sua incisiva sinuosità
si adatta ad ambienti minimali
e ricchi di stile.

È progettato per favorire il comfort
nelle occasioni di condivisione,
dalle riunioni ai momenti di relax.

Eon ha una seduta ampia,
avvolgente e confortevole racchiusa
in una forma geometrica distintiva.

EON

Plus Design / 2011

141

EON

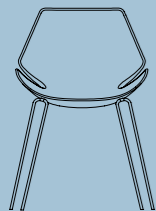

Designed by Plus Design, EON is a uniquely versatile seating system. With its incisive slinkiness it adapts to both minimalist and very stylish settings. It is designed to promote comfort in all moments of sharing, from meetings to rest periods. Hospitable and enveloping, Eon has a generously comfy seat enclosed in distinctively geometric patterns.

Conçu par Plus Design, EON est un système d'assise singulier et polyvalent. Avec sa sinuosité incisive il s'adapte aux environnements minimalistes et plein de style. Il est conçu pour favoriser le confort dans tous moments de partage, de la réunions à la pause. Accueillant et enveloppant, Eon a une grande assise dans des formes géométriques distinctifs.





Eon visitor chair / Blazer CUZ28 / Blazer CUZ28 - Ikon 130 / Panna - Moka / Blazer CUZ30



Eon visitor chair / Antracite / Bianco

EON



Eon visitor chair / Bazer CUZ28 - Ikon 130



Eon visitor stool / Bianco - Tortora



EON

Plus Design / 2011

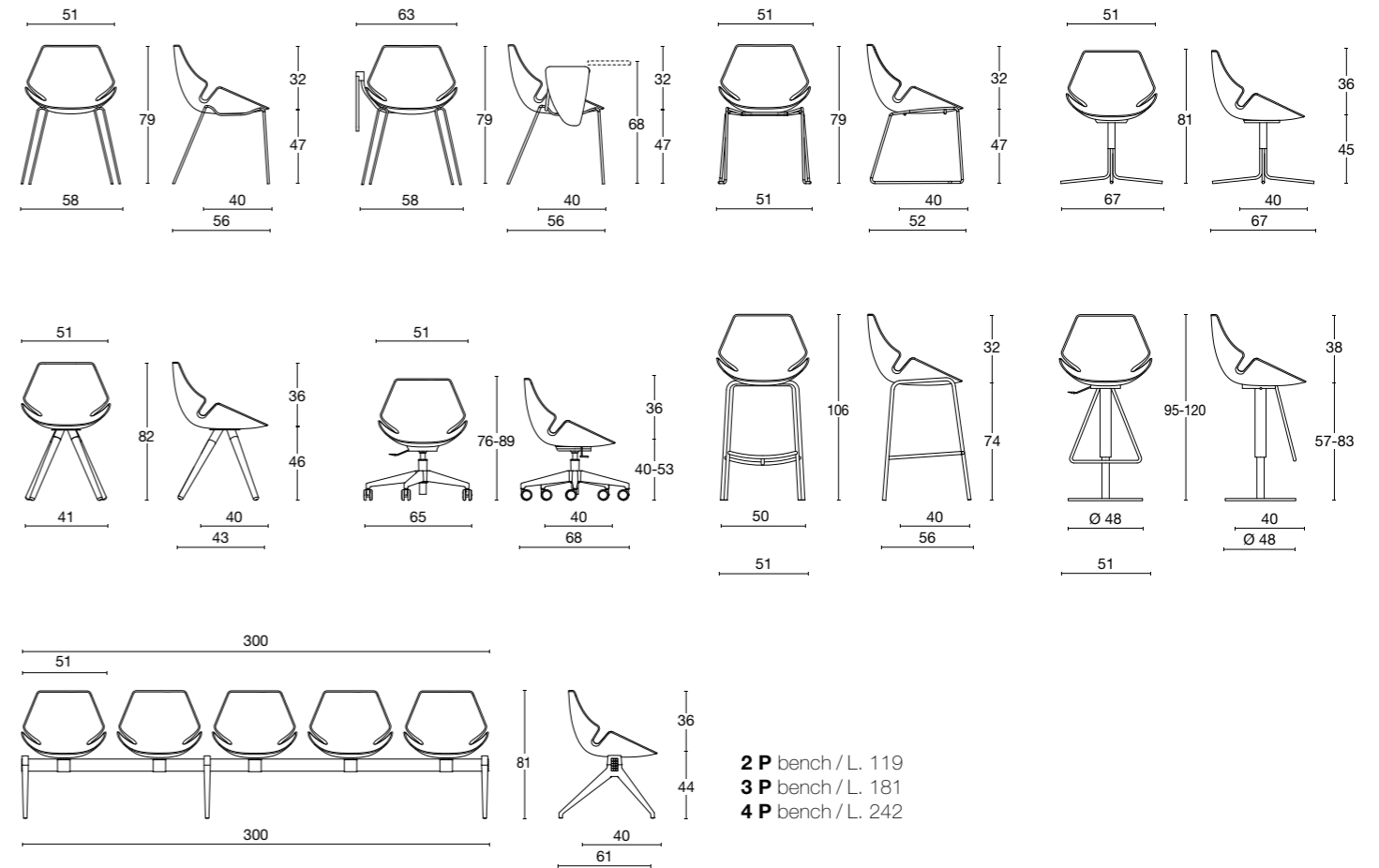

Sedia ideale per il mondo contract, ufficio e per il settore casa. Scocca in poliuretano rigido TECH, colorato. Disponibile su telaio 4 gambe cromato, su telaio slitta cromato o nero o ancora su 4 gambe in legno di frassino, su gas e base a 5 razze in alluminio con ruote o su telaio girevole in tubolare d'acciaio. Versione su panca da 2/3/4/5 posti. Sgabello fisso con telaio cromato o con gas e base rotonda cromata. La scocca può essere anche imbottita e rivestita.

Just the chair for the contract, office or home. Body in coloured rigid TECH polyurethane. Available: on 4 chromed legs; on a chromed or black sled base; on 4 wooden legs in ash; on a 5-spur aluminium base with gaslift and castors; or on a tubular steel base with swivel. Also available as a barstool on chromed sled; or as two, three, four or five-seater beam units. Fixed stool with chromed frame; or with gaslift on a round chromed base. The shell can also be upholstered.

Chaise idéale pour le monde du contract, le bureau et le secteur domestique. Coque en polyuréthane rigide TECH, colorée. Disponible sur piètement 4 pieds chromé, piètement luge chromé ou noir ou sur 4 pieds en bois base en frêne, gaz et base 5 rayons en aluminium avec roulettes ou sur piètement acier tubulaire pivotant. Version sur poutre 2/3/4/5 places. Tabouret fixe avec structure chromée ou gaz et base ronde chromée. La coque peut également être rembourrée et recouverte.

struttura
 poliuretano Tech / acciaio

base cromata / verniciata nera / alluminio lucido

rivestimento
 tessuto

pelle
 ecopelle

frame
 Tech polyurethane / steel

base: chromed / lacquered black / polished aluminum

upholstery
 fabric

genuine leather
 faux leather

structure
 Tech polyuréthane / acier

base en aluminium poli / chromé / peint en noir

revêtement
 tissu

cuir
 simili cuir



Eon visitor chair / Bianco

VANITY è raffinata e lineare.

In questa seduta ampia e confortevole sono evidenti le geometrie simmetriche ed essenziali. Le cuciture dell'imbottitura convergono verso il foro ellittico al centro. Nella sua comodità e modernità, Vanity è l'ideale anche per una seduta prolungata.

VANITY

Diemme Lab / 2007

155

VANITY

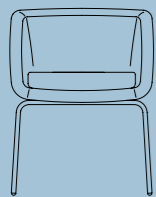

VANITY is refined and linear. The generously comfortable seat displays tightly symmetrical geometry: the curves of the upholstery converge towards the centre detail, a hole in the elliptical shape of the chair itself. In its comfort and modernity, Vanity is ideal for both leisure and extended use.

VANITY raffiné et linéaire. Dans ce siège large et confortable la géométrie symétrique est évidente et essentielle: les courbes du rembourrage convergent vers le détail positionné au centre, un trou elliptique. Dans son confort et sa modernité, Vanity est idéal pour les moments de loisirs ou d'attente prolongée.



Vanity visitor chair / Gorgeous 2111 - 2158 - 2152 - 2140

VANITY



Vanity visitor chair / Gorgeous 2140

VANITY

Diemme Lab / 2007



Vanity visitor chair / Gorgeous 2140

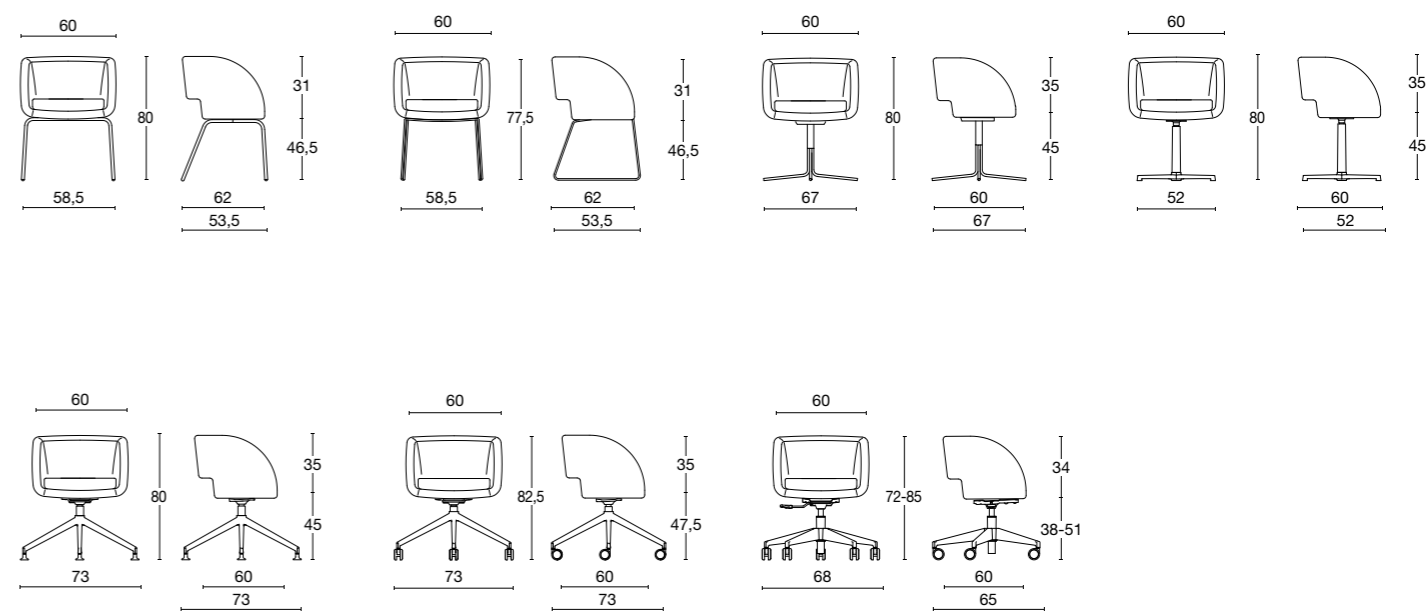

Poltroncina d'attesa e riunione con meccanismo a gas o telaio slitta, 4 gambe, 4 razze in tubolare d'acciaio o 4 razze in alluminio con meccanismo di ritorno o ancora su base piramidale verniciata nera o bianca.

Waiting and meeting armchair with gas mechanism; or sled frame; four legs; four tubular steel spokes; four aluminum spokes with swivel and return mechanism; or black or white lacquered pyramid base.

Fauteuil d'attente et de réunion avec mécanisme à gaz ou structure luge, 4 pieds, 4 rayons en tube d'acier ou 4 rayons en aluminium avec mécanisme de retour ou base pyramidale peinte en noir ou blanc.



struttura
acciaio



base cromata / alluminio lucido / verniciata nera / verniciata bianca



rivestimento
tessuto



pelle
ecopelle

frame
steel

base: polished aluminum / black lacquered / white lacquered / chromed

upholstery
fabric

genuine leather
faux leather

structure
acier

base chromé / aluminium poli / peint en noir / peinte en blanc

revêtement
tissu

cuir
simili cuir

Progettata da DorigoDesign,
MARGARITA è una compagna
perfetta nei momenti di relax
e di condivisione.

Disponibile con cuscino imbottito
o imbottitura completa, oppure
in versione nuda, è adatta
sia agli ambienti interni
che agli spazi outdoor.

La forma ampia e la seduta spaziosa
si combinano con un design
fresco e contemporaneo.

MARGARITA **165**

DorigoDesign / 2016

MARGARITA

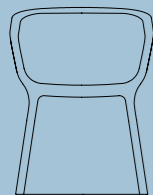

By DorigoDesign, MARGARITA is a slinky chair with rounded shapes and is the perfect companion in moments of relax and interaction. It is available with a seatpad, fully upholstered, or without any upholstery at all, in which version it can be used indoors or out. Margarita's wide shape and spacious seat combine with fresh and contemporary design.

Conçu par DorigoDesign, MARGARITA est un siège avec formes sinueuses et arrondies est un parfait compagnon dans des moments de détente et d'échange. Il est disponible avec un coussin rembourré ou un rembourrage complet ou version nue, pour lequel il convient à l'intérieur qu'aux espaces extérieurs. La forme large et l'assise spacieuse de Margarita se combine avec un design frais et contemporain.



Margarita visitor chair / Cube 2001 - Blazer CUZ39 / Cube 2001 - Blazer CUZ28 / Antracite

MARGARITA

MARGARITA

DorigoDesign / 2016

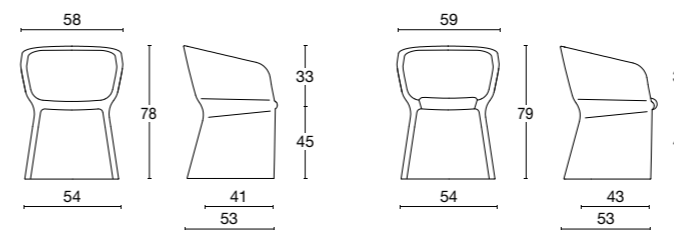

Poltroncina dalle linee moderne, ideale per sale d'attesa e riunione. Disponibile in polietilene colorato in diverse tonalità (bianco, tortora, antracite, rosso, verde e giallo) adatta ad un utilizzo anche outdoor, o con cuscinetto accessorio imbottito e rivestito, oppure ancora totalmente rivestita.

Armchair with modern lines, ideal for waiting and meeting rooms. Available in coloured polyethylene in different shades (white, taupe, anthracite grey, red, green and yellow) suitable also for outdoor use, or with seatpad, or fully upholstered.

Fauteuil aux lignes modernes, idéal pour les salles d'attente et de réunion. Disponible en polyéthylène coloré dans différentes nuances (blanc, taupe, anthracite, rouge, vert et jaune) adapté pour une utilisation en extérieur, ou avec coussin accessoire rembourré, ou totalement recouvert.



struttura
polietilene



piedini polipropilene



rivestimento
tessuto



pelle
ecopelle

frame

polyethylene

base: polypropylene feet

upholstery

fabric

genuine leather
faux leather

structure

polyéthylène

pieds en polypropylène

revêtement

tissu

cuir
simili cuir

MISTER è una rivisitazione contemporanea e innovativa della poltrona tradizionale. Ne conserva il comfort e l'eleganza ma si libera del superfluo assumendo una forma leggera e minimalista. È l'ideale per sale riunioni e sale d'attesa moderne e distinte. Questa seduta dal gusto classico è una scelta all'avanguardia, raffinata e razionale.

MISTER
Diemme Lab / 2007

173

MISTER

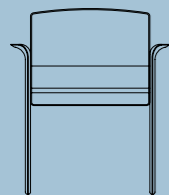

MISTER is a contemporary and innovative reinterpretation of the traditional armchair. It retains the comfort and elegance but does away with the superfluous, taking on a light and minimalist form. It is ideal for bold and modern waiting and meeting rooms. In this chair, comfort sits alongside classical style. Mister is a cutting edge choice, refined and rational.

MISTER est une réinterprétation en design contemporain et innovant d'une fauteuil classique. Il conserve son confort et son élégance mais se débarrasse du superflu et prend une forme légère et minimaliste. Il est idéal pour les salles de réunion, salles d'attente modernes et distinctes. Dans ce petit fauteuil, le confort va avec le goût du classique. Mister est un choix raffiné et rationnel.

MISTER

Diemme Lab / 2007



Mister visitor armchair / Planet 991.133

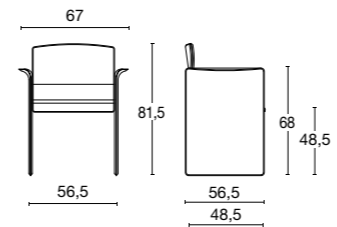

Poltroncina dalla forma elegante ed essenziale giusta alternativa alla tradizionale poltrona per visitatore, struttura in multistrato di faggio e barre in acciaio indeformabile, imbottitura in poliuretano espanso, e braccioli fissi.

Armchair with an elegant and essential shape, the ideal alternative to traditional visitor armchairs, with a beech plywood frame, non-deformable steel bars, polyurethane foam padding, and fixed armrests.

Fauteuil avec une forme élégante et essentielle, juste une alternative à un fauteuil visiteur classique, structure en contreplaqué de hêtre et barres d'acier indéformables, rembourrage en mousse de polyuréthane, et accoudoirs fixes.



struttura
multistrato di faggio



base cromata



rivestimento
tessuto



pelle
ecopelle

frame
beech plywood

base: chromed feet

upholstery
fabric

genuine leather
faux leather

structure
contreplaqué de hêtre

base chromée

revêtement
tissu

cuir
simili cuir

CHAT, disegnato da Diemme Lab,
è uno sgabello dal design moderno
e contemporaneo, ideale per aree
collaborative e break.

La struttura è caratterizzata dalla
doppia silhouette del poggiatesta.
Le sue linee leggere e minimaliste
rendono accattivanti anche
gli ambienti più sobri.

CHAT

Diemme Lab / 2020

179

CHAT

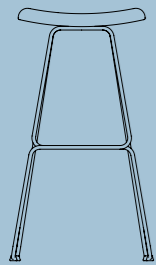

The modern CHAT barstool is designed by Diemme Lab. Its contemporary look makes it ideal for groupwork and breakout areas. The double shape of the footrest characterises the frame, whilst the light and minimalist lines set off even the most sober of rooms.

CHAT conçu par Diemme Lab est un tabouret au design moderne et contemporain, idéal pour les espaces collaboratifs et de pause. La double silhouette du repose-pieds caractérise la structure, les lignes légères et minimalistes le rendent attrayant même dans les pièces les plus sobres.

CHAT

CHAT

Diemme Lab / 2020



Chat visitor stool / Jet 7025

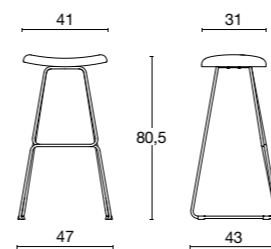

Sgabello ideale per aree collaborative e break.
Seduta in multistrato di faggio e imbottitura in poliuretano espanso. Telaio fisso in metallo verniciato nero o bianco.

An ideal stool for groupwork and breakout areas.
Beech ply seat with polyurethane foam padding.
Fixed metal frame lacquered black or white.

Tabouret idéal pour les espaces collaboratifs et de pause.
Assise en contreplaqué de hêtre et rembourrage en mousse de polyuréthane. Cadre fixe en métal peint noir ou blanc.



struttura
multistrato di faggio



base in acciaio verniciata nera / verniciata bianca



rivestimento
tessuto



pelle
ecopelle

frame

beech plywood

base: black lacquered steel / white lacquered steel

upholstery

fabric

genuine leather
faux leather

structure

contreplaqué de hêtre

piètement en acier peint noir / blanc

revêtement

tissu

cuir
simili cuir

PRINCE è uno sgabello fine,
dal gusto contemporaneo.
La seduta è regolabile in altezza
per adattarsi a tutti i piani di lavoro.
Il poggiapiedi cromato
dona simmetria alla morbida
silhouette, disponibile nella versione
con schienale alto e basso.
In entrambi i modelli, la postura
è supportata da una leggera
ed elegante curvatura della seduta.

PRINCE

Diemme Lab / 2007

185

PRINCE

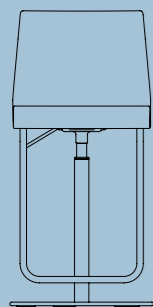

PRINCE is a slender stool, with a contemporary feel. The seat is height-adjustable to adapt to all kinds of worktops. The chromed footrest gives symmetry to the soft outline both in versions with high and low backrest. Even the low-back seat assures a degree of posture through its slight and elegant tail-lift.

PRINCE est un beau tabouret, avec un goût contemporain. L'assise est réglable en hauteur s'adapte aux plans de travail de différents types. Le repose-pieds chromé donne la symétrie au soft silhouette à la fois dans la version avec dossier haut que celle avec le bas dossier. Même dans ce dernier cas, la posture est soutenue par une légère courbure de l'assise.

PRINCE

Diemme Lab / 2007



Prince visitor stool / Wolin 7050.22

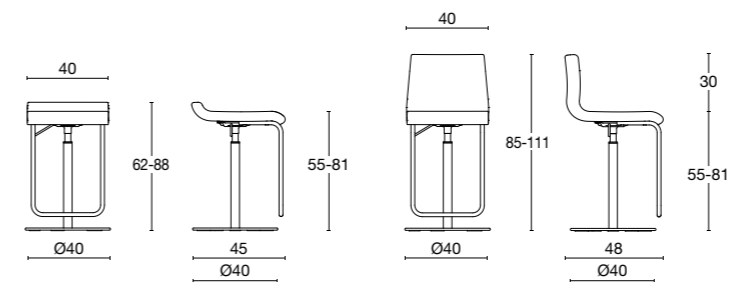

Sgabello dalla linea morbida e sinuosa, con monoscocca in multistrato di faggio con schienalino alto o basso, rivestimento in pelle e tessuti. Elevazione a gas e base tonda cromata con appoggiapiedi in tubolare d'acciaio.

Stool with soft and sinuous lines, with beech ply shell with high or low back, upholstery in leather or fabric. Gas-lift and round chromed base with steel tube footrest.

Tabouret avec une ligne douce et sinueuse, avec monocoque en contreplaqué de hêtre avec dossier haut ou bas, revêtement en cuir et tissus. Elevation gaz et base ronde chromée avec repose-pieds tubulaire acier.



struttura
multistrato di faggio



base cromata



rivestimento
tessuto



pelle
ecopelle

frame

beech plywood

base: chromed

upholstery

fabric

genuine leather
faux leather

structure

contreplaqué de hêtre

base chromée

revêtement

tissu

cuir
simili cuir

RED HOT si distingue
per lo schienale sagomato
con il caratteristico taglio centrale
e l'insolita curvatura laterale.
È adatto ad arredare spazi
anticonformisti e a dare
un tocco di brio
ad ambienti più sobri.

RED HOT

Diemme Lab / 2017

191

RED HOT

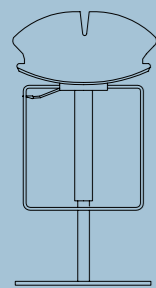

RED HOT is distinguished by its shaped back with feature central cut, which preserves its identity thanks to the unusual side curves. The Red Hot stool is suitable both to furnish casual and chill areas as well as to give a touch of panache to more sober rooms.

RED HOT se démarque par son dossier bas avec la coupe centrale caractéristique, qui garde son identité grâce à la courbure latérale. Le tabouret Red Hot convient à la fois pour meubler les espaces de socialisation non conformiste à la fois pour donner une touche de vivacité dans des pièces plus sobres.

RED HOT

Diemme Lab / 2017



Red Hot visitor stool / Nero

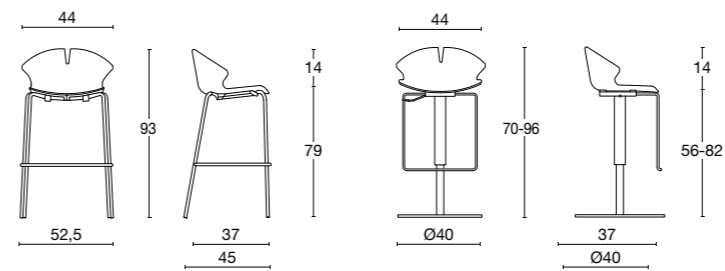

Sgabello a 4 gambe cromato o a basamento centrale con alzata gas. Scocca in polipropilene colorato: bianco, azzurro, giallo o antracite.

Barstool with 4 chromed legs or central base with gas lift. Coloured polypropylene shell: white, blue, yellow or anthracite.

Tabouret avec 4 pieds chromés ou base centrale avec vérin à gaz. Assise en polypropylène coloré: blanc, bleu, jaune ou anthracite.



struttura
polipropilene

base cromata

frame
polypropylene

base: chromed

structure
polypropylène

base chromée

Rivestimenti
Upholstery | Nuanciers

JET / CAT. F

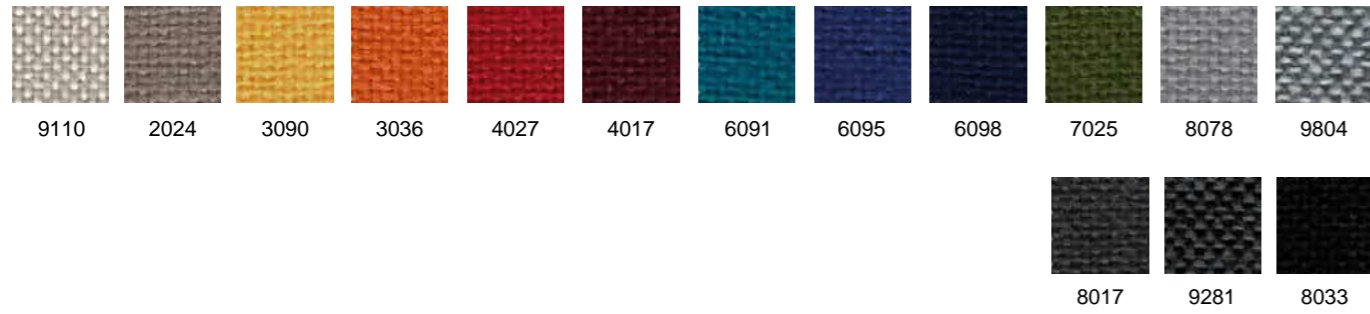

ERA / CAT. S



PLANET - SURROUND / CAT. F



IKON / CAT. TOP

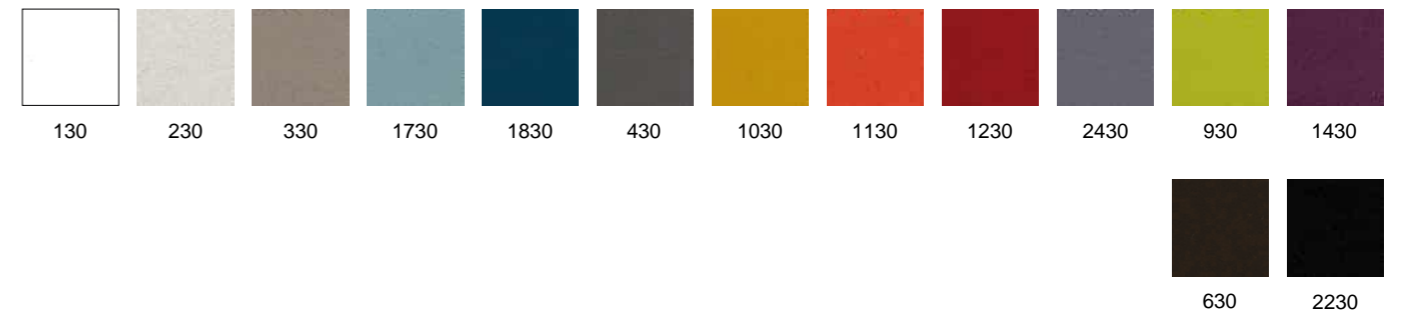

BINGO ELAST - MIRAGE / CAT. G

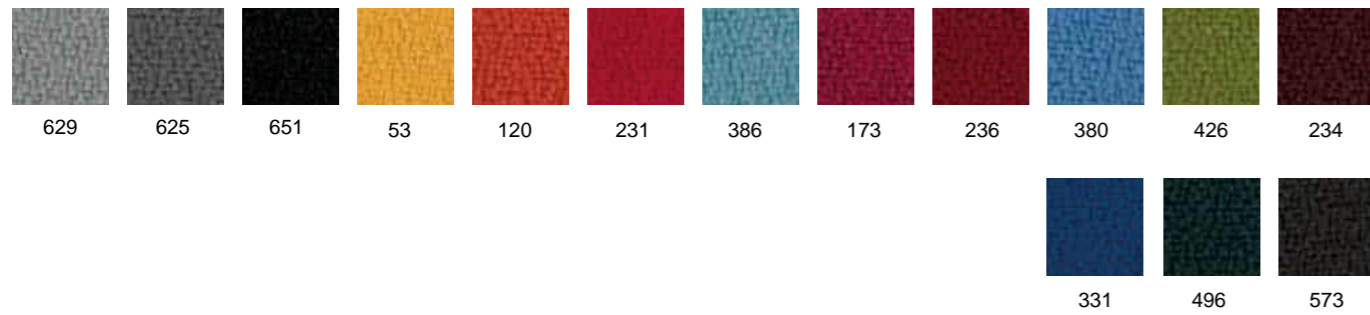

BLAZER / CAT. EXTRA



CUBE / CAT. G

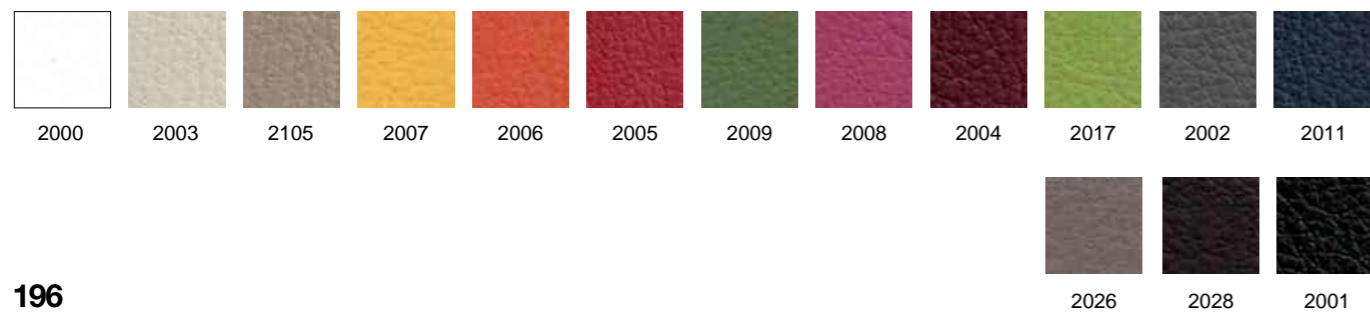

GORGEOUS / CAT. EXTRA

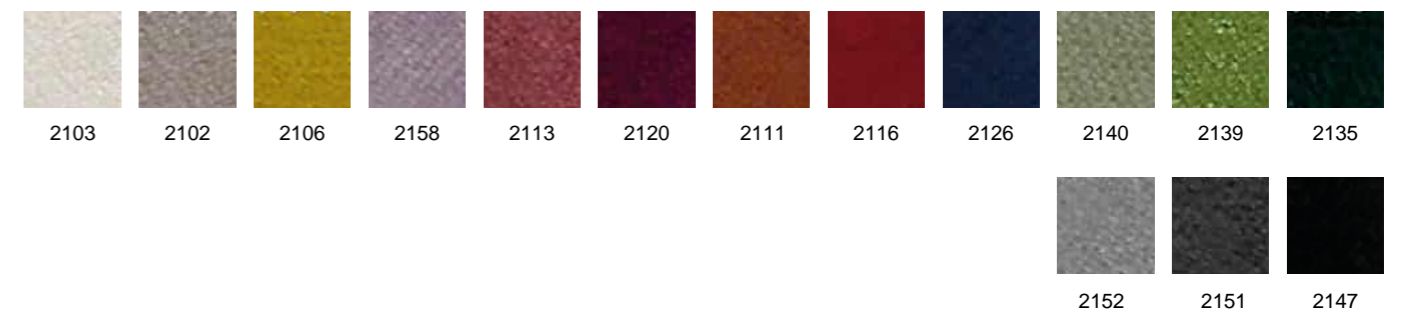

HESTAN / CAT. EXTRA

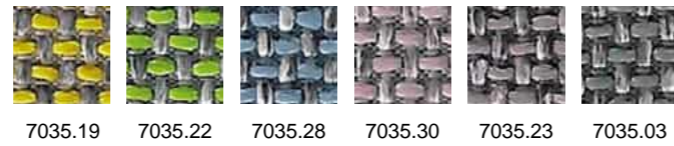

SEDIA IN CUOIO | Hide | Cuir sellier / CLOP



WOLIN / CAT. EXTRA

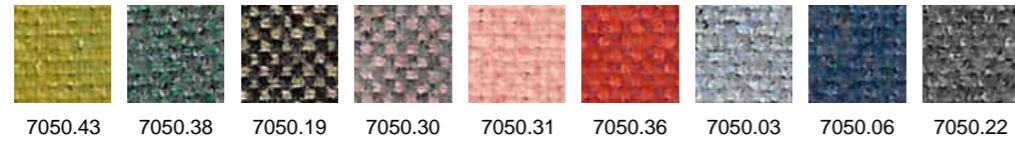

RETI | Mesh | Résille / AUCKLAND

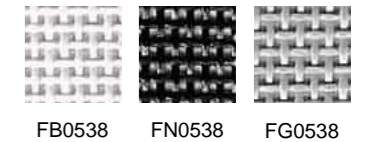

POLO / CAT. FIESTA

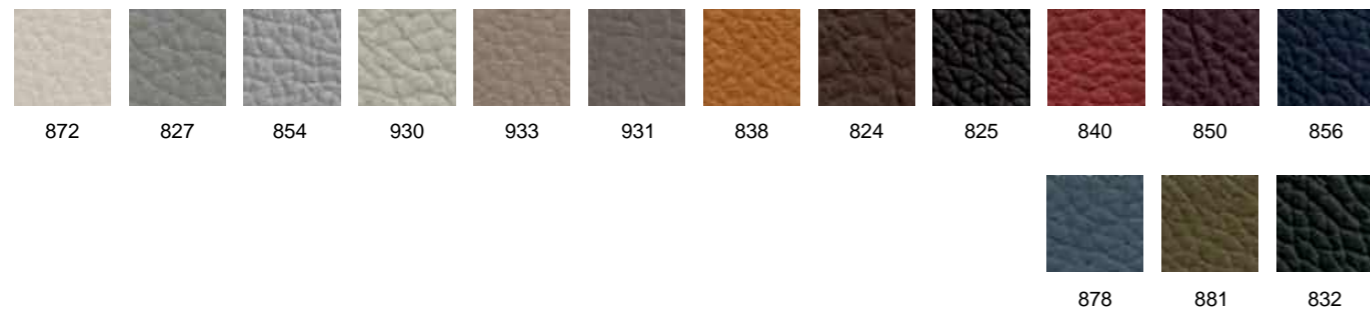

RETI | Mesh | Résille / GOAL / HOP / LEAD / NEW BONN / SOCIAL

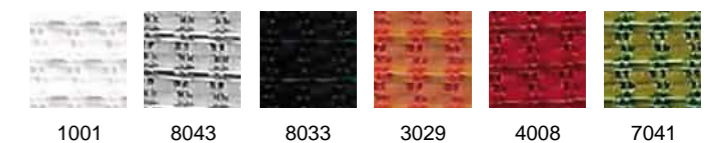

FIESTA



RETI | Mesh | Résille / LIBERTY

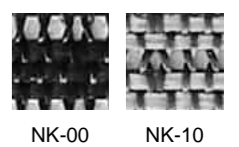

NUVOLA

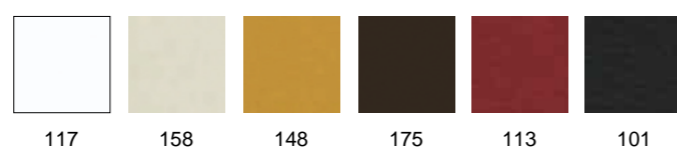

RETI | Mesh | Résille / FIT / SOCIAL



POLIPROPILENE | Polypropylene | Polypropylène / NEW BONN

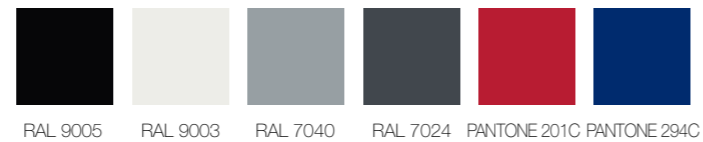

POLIPROPILENE | Polypropylene | Polypropylène / CLOP



POLIPROPILENE | Polypropylene | Polypropylène / NO FRILL

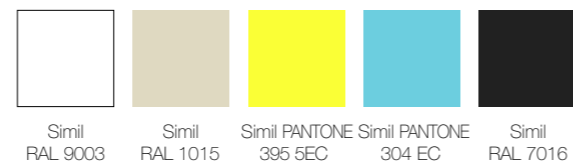

POLIURETANO RIGIDO TECH | Tech polyurethane | Tech polyuréthane / EON

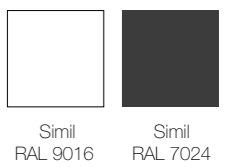

POLIPROPILENE | Polypropylene | Polypropylène / NUKE



COLORI BICOLOR | Two-colors shell | Coque bicolore / EON

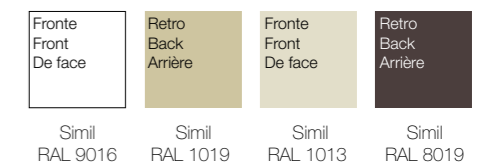

POLIPROPILENE | Polypropylene | Polypropylène / REDHOT



POLIETILENE SEDIA | Polyethylene chair | Polyéthylène chaise / MARGARITA



POLIPROPILENE | Polypropylene | Polypropylène / SLIM

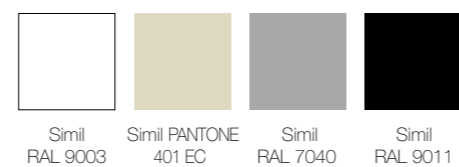

POLIETILENE TAVOLO | Polyethylene table | Polyéthylène table / MARGARITA

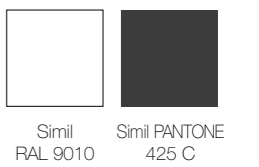

POLIPROPILENE | Polypropylene | Polypropylène / SUNNY NEW

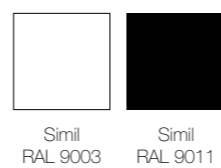



Distributor pro ČR a SK
www.mintiga.cz
obchod@mintiga.cz
+420 724 124 042

Art direction: Priority Design

Graphic design concept: Priority Design

Photo: Arch. Prior Vinicio

Styling: Baliviera Enrica

Post production: Priority Design

Printed by: Graficart Arti Grafiche

Thanks to: Artemide | Axia | Brionvega | Campana Moquette | Cini&Nils | Joe Colombo | Seletti | Venini

09/2020

Diemme Srl

Via del Lavoro, 25 | 31013 Codognè TV | Italy

T. +39 0438 778211

F. +39 0438 479836

dm@diemmeoffice.com

www.diemmeoffice.com

Diemme.