

lounge area



Distributor pro ČR a SK
www.mintiga.cz
obchod@mintiga.cz
+420 724 124 042

Diemme.

3

furniture to
connect people

Lavoriamo dove siamo nati

We work where we were born | Nous travaillons où nous sommes nés

4

Comfort e Sostenibilità

Comfort and Sustainability | Confort et Durabilité

6

Collezioni

Collections | Les Collections

9

Rivestimenti

Upholstery | Nuanciers

193

LAVORIAMO
DOVE
SIAMO NATI

Non abbiamo mai inaugurato ufficialmente Diemme, sarebbe come dire: “Missione compiuta... lavoro terminato... possiamo rilassarci”.

Finirebbe per intorpidirci, quando invece per noi Diemme è un progetto in continua evoluzione, su cui riversare la nostra dedizione ogni giorno. Dopo più di vent’anni di attività ci sentiamo a casa.

Ci siamo conosciuti nel 1985. Entrambi lavoravamo nel settore dell’imbottito, ma in due aziende diverse. Poi siamo diventati colleghi. Nel corso del tempo si è creato tra noi un rapporto di profondo rispetto e amicizia, indispensabile per intraprendere un’attività insieme. Nel 1995 in una giornata fredda d’inverno, dopo una delle nostre lunghe chiacchierate, abbiamo deciso di unire le forze e dar vita a Diemme.

L’azienda nasce lavorando per conto di terzi, ma la nostra visione è sempre stata quella di dedicarci alla creazione di un sistema coerente di sedute tutte nostre. Dopo aver disegnato e realizzato con passione la nostra prima seduta da ufficio, è stato chiaro che quella era la strada da seguire. In poco tempo è uscito il nostro primo catalogo, a cui hanno fatto seguito i primi successi. Come dimenticare la nostra prima fiera. Sono passati molti anni, ma il ricordo di vedere i nostri prodotti introdotti nel mondo office rimane indelebile.

Come tutti, anche noi abbiamo attraversato gli anni della crisi, ma siamo ugualmente cresciuti grazie a scelte coraggiose e ben precise: collaborare con architetti e designer, e ampliare la visione del mondo office affiancando divani e poltroncine alle sedute che già producevamo.

La forza di Diemme è ciò che ci circonda: il territorio in cui siamo nati e in cui ancora operiamo, i nostri partner locali, le persone che ci sono sempre state vicino. Grazie a loro abbiamo trovato il coraggio di guardare lontano, affrontare nuovi progetti, aprirci a nuovi mercati.

Siamo rimasti umili e concreti, ma allo stesso tempo ambiziosi di trasformare le nostre collezioni in un sistema di prodotti versatili e adatti ad ogni ambiente. Forse può sembrare un luogo comune, ma due menti sono davvero meglio di una. Esperienze diverse, punti di vista diversi, personalità diverse; Diemme è cresciuta come azienda perché ci siamo sempre impegnati a vedere oltre alle nostre differenze e a trovare un punto d’unione. Questo è il nostro pensiero.

WE WORK
WHERE
WE WERE
BORN

We have never officially inaugurated Diemme, it would be like saying: “Mission accomplished... job done... time to relax”. It would end up numbing us, when instead, to our way of thinking, Diemme is a project in continuous evolution, which we smother with our dedication every day. After more than twenty years of activity, we feel at home.

We met in 1985, we both worked in the upholstery trade, but in two different companies. Then we became colleagues. Over time, a relationship of deep respect and friendship developed between us, essential for embarking on any joint venture. On a cold winter’s day in 1995, after one of our long chats, we decided to join forces and give life to Diemme.

At first, Diemme worked for third parties, but our vision was always to dedicate ourselves to creating a coherent seating system all our own. After designing and creating our first office chair with passion, it was clear that this was the way forward. In a short time our first catalogue was released, followed by the first successes. How can we forget our first fair. Many years have passed, but the memory of seeing our products introduced into the office world remains indelible.

Like everyone else, we too have gone through the years of crisis, but we have equally grown thanks to courageous and precise choices: collaborating with architects and designers, and widening the vision of the office world by introducing sofas and armchairs alongside the seating we already produced. The strength of Diemme is what surrounds us: the territory in which we were born and where we still operate, our local partners, the people who have always been close to us. Thanks to them, we found the courage to look far, face new projects, open up to new markets. Though remaining humble and concrete, we are at the same time ambitious to transform our collections into a system of versatile products suited to any environment. It may sound like a cliché, but two heads really are better than one. Different experiences, different points of view, different personalities; Diemme has grown as a company because we have always been committed to seeing beyond our differences and finding a meeting point. This is the way we see it.

NOUS
TRAVAILLONS
OÙ NOUS
SOMMES NÉS

Nous n’avons jamais officiellement inauguré Diemme, ce serait comme dire: “Mission accomplie... travail terminé... on peut se détendre”. Cela finirait par nous engourdir, alors qu’au contraire pour nous Diemme est un projet en évolution continue, sur lequel verser notre dévouement quotidien. Après plus de vingt ans d’activité, nous nous sentons chez nous.

Nous nous sommes rencontrés en 1985, nous travaillions tous les deux dans le secteur du rembourrage, mais dans deux entreprises différentes. Ensuite, nous sommes devenus collègues. Au fil du temps, une relation de profond respect et d’amitié s’est nouée entre nous, indispensable pour entreprendre ensemble une entreprise. En 1995, par une froide journée d’hiver, après l’une de nos longues conversations, nous avons décidé d’unir nos forces et de donner vie à Diemme.

L’entreprise a été fondée en travaillant pour des autres sociétés, mais notre vision a toujours été de créer un système cohérent de sièges qui nous est propre. Après avoir conçu et créé notre premier siège de bureau avec passion, il était clair que c’était la voie à suivre. En peu de temps, notre premier catalogue est sorti, suivi des premiers succès. Comment oublier notre première foire. De nombreuses années ont passé, mais la mémoire de voir nos produits introduits dans le monde du bureau reste indélébile.

Comme tout le monde, nous avons aussi traversé les années de la crise, mais nous nous sommes également développés grâce à des choix courageux et précis: collaborer avec les architectes et les designers, élargir la vision du monde du bureau en plaçant canapés et fauteuils à côté des sièges que nous avons déjà produits. La force de Diemme, c’est ce qui nous entoure: le territoire dans lequel nous sommes nés et dans lequel nous opérons encore, nos partenaires locaux, les gens qui ont toujours été proches de nous. Grâce à eux, nous avons trouvé le courage de regarder loin, de faire face à de nouveaux projets, de nous ouvrir à de nouveaux marchés. Nous sommes restés humbles et concrets, mais en même temps ambitieux de transformer nos collections dans un système de produits polyvalents adaptés à tout environnement. Cela peut sembler banal, mais deux esprits valent vraiment mieux qu’un. Différentes expériences, différents points de vue, différentes personnalités; Diemme a grandi parce que nous nous sommes toujours engagés à voir au-delà de nos différences et à trouver un point de rencontre. Telle est notre pensée.

COMFORT E SOSTENIBILITÀ

L'innovazione vera e propria permette di soddisfare le esigenze sia attuali che future.

Siamo chiamati ad affrontare le sfide quotidiane con atteggiamento reattivo e propositivo, andando alla ricerca di nuove soluzioni creative senza soffermarci per inerzia su procedimenti obsoleti. Gli spazi entro cui ci muoviamo devono, quindi, plasmarsi su di noi perché si crei una sinergia tra pensiero ed espressione, interiorità ed esteriorità. Non dovremmo percepire alcuna dissonanza tra il nostro desiderio di crescere e la qualità dell'ambiente che ci circonda.

Ogni giorno ci mettiamo in gioco per facilitare e migliorare la vita di altre persone. Proprio per questa ragione, lo spazio intorno a noi non deve adattarsi solo alle nostre esigenze correnti ma anche ai bisogni delle generazioni future.

Scegliere una seduta che garantisce un supporto corretto è un modo semplice e diretto di migliorare la qualità del tempo e favorire il benessere. Per garantire questo servizio, eseguiamo controlli in tutte le fasi di produzione seguendo un sistema di gestione della qualità certificato ISO 9001. Oltre a offrire il giusto supporto ergonomico, proponiamo ampie possibilità di personalizzazione per rispondere al bisogno umano, sempre sentito, di unicità e bellezza.

Ci assicuriamo che tutti i materiali che utilizziamo siano di origine locale per ridurre gli sprechi e favorire quindi la crescita di un mercato "verde". In fase di progettazione, cerchiamo i percorsi migliori per realizzare prodotti a ridotto impatto ambientale lungo l'intero ciclo di vita. Grazie a queste accortezze, semplici ma significative, due delle nostre sedute hanno ottenuto la certificazione promossa dal Green Public Procurement, ovvero il nuovo approccio Europeo agli acquisti ecosostenibili.

COMFORT AND SUSTAINABILITY

True innovation should meet both current and future needs.

We are called to face daily challenges with a reactive and proactive attitude, going in search of new creative solutions without dwelling on inertia on obsolete procedures. The spaces in which we move must, therefore, mold themselves around us to create a synergy between thought and expression, interior and exterior. We should not perceive any friction between our desire to grow and the quality of the environment around us.

Every day we roll our sleeves up to facilitate and improve the lives of other people. Precisely for this reason, the space around us ought not only to adapt to our current needs but also to those of future generations.

Choosing a chair that guarantees correct support is a simple and direct way of improving the quality of time and promoting well-being. To ensure this, we carry out checks at all stages of production following an ISO 9001 certified quality management system. In addition to offering the right ergonomic support, we offer extensive customization options to respond to the ever-present human hunger for uniqueness and beauty.

We make sure that all the materials we use are of local origin to reduce waste and therefore encourage the growth of a "green" market. During the design phase, we look for the best ways to create products with reduced environmental impact throughout their entire life cycle. Thanks to these simple but significant precautions, some Diemme chairs have obtained Green Public Procurement certification, being the new European approach to eco-sustainable purchases.

CONFORT ET DURABILITÉ

L'innovation actuelle nous permet de répondre aux besoins actuels et futurs.













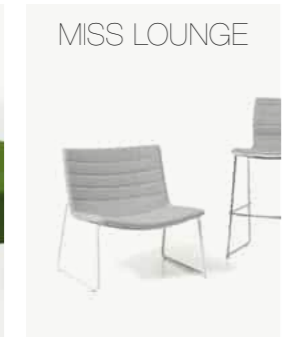
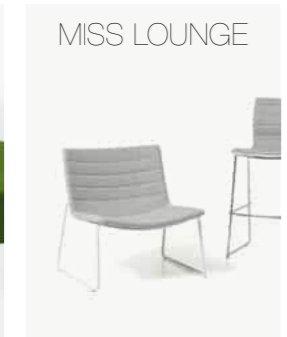

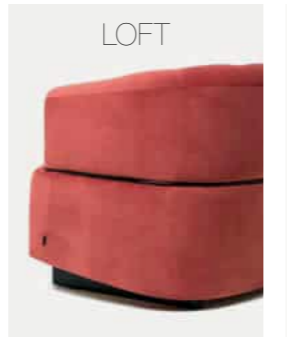
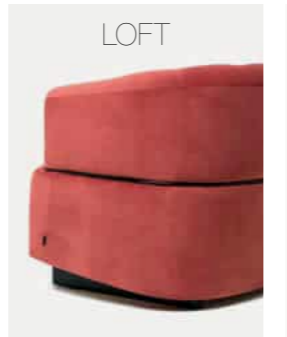





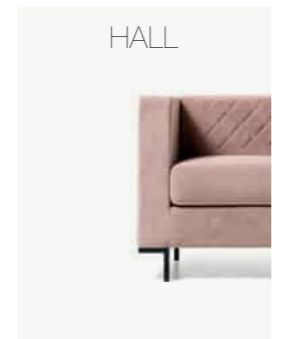
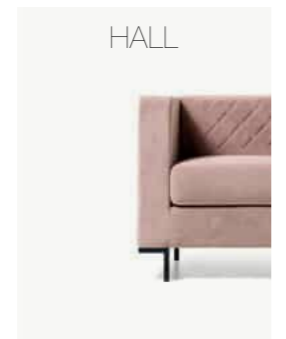
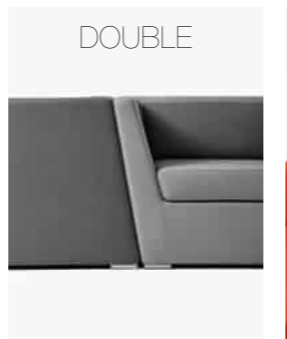
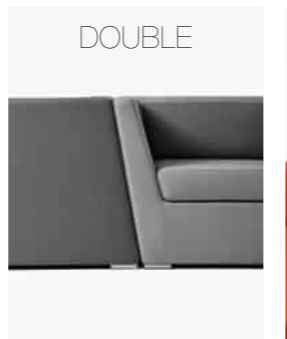



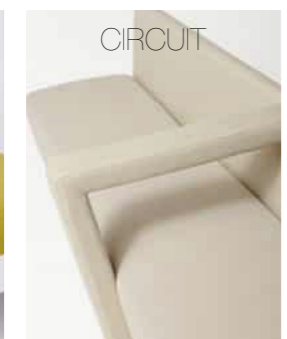
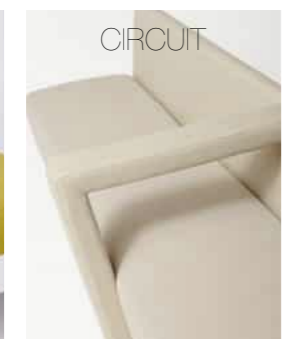
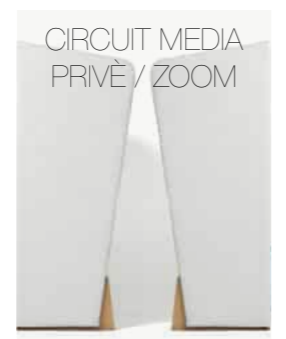
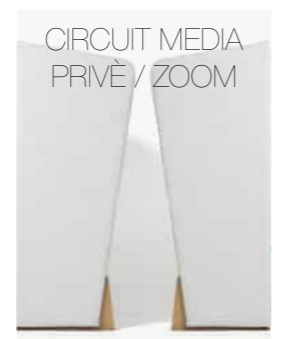

Nous sommes appelés à faire face aux défis quotidiens avec une attitude réactive et proactive, à la recherche de nouvelles solutions créatives sans insister sur les procédures obsolètes. Les espaces dans lesquels nous évoluons doivent donc se modeler sur nous afin de créer une synergie entre pensée et expression, intériorité et extériorité. Nous ne devons percevoir aucune dissonance entre notre envie de grandir et la qualité de l'environnement qui nous entoure.

Chaque jour, nous nous impliquons pour faciliter et améliorer la vie des autres. C'est précisément pour cette raison que l'espace qui nous entoure doit non seulement s'adapter à nos besoins actuels mais aussi aux besoins des générations futures.

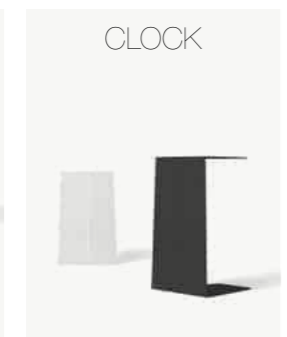
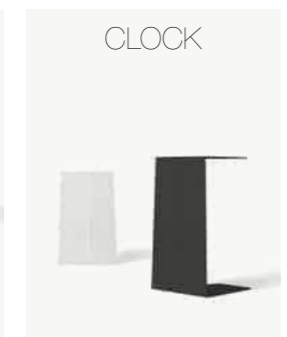
Choisir un siège qui garantit un soutien correct est un moyen simple et direct d'améliorer la qualité du temps et de favoriser le bien-être. Pour garantir ce service, nous effectuons des contrôles à toutes les étapes de la production selon un système de gestion de la qualité certifiée ISO 9001. En plus d'offrir le bon support ergonomique, nous proposons de nombreuses options de personnalisation pour répondre au besoin humain d'unicité et de beauté.

Nous prenons garde à tous les matériaux que nous utilisons qu'ils soient d'origine locale pour réduire les déchets et donc favoriser la croissance d'un marché «vert». Pendant la phase de conception, nous recherchons les meilleures façons de créer des produits à impact environnemental réduit tout au long du cycle de vie. Grâce à ces précautions simples mais importantes, certains de nos sièges ont obtenu la certification promue par Green Public Procurement, qui est la nouvelle approche européenne pour les achats éco-durables.

LOUNGE AREA

 <p>CIRCUIT POUF</p> 	 <p>MISS LOUNGE</p> 	 <p>EON LOUNGE</p> 	 <p>LOFT</p> 	 <p>TOFFEE</p> 
15	23	31	39	49
 <p>JAZZ</p> 	 <p>FRAME</p> 	 <p>HALL</p> 	 <p>DOUBLE</p> 	 <p>CROSS</p> 
57	65	71	79	87
 <p>BREAD</p> 	 <p>CIRCUIT</p> 	 <p>CIRCUIT MEDIA PRIVÉ / ZOOM</p> 	 <p>SNAKE</p> 	 <p>BREAD</p> 
95	107	121	137	155
 <p>CIRCUIT</p> 	 <p>CLOCK</p> 	 <p>XL XS</p> 	 <p>MARGARITA</p> 	 <p>ROCK</p> 
163	169	175	181	187

Collezioni
Collections | Les collections

Le nostre collezioni rispecchiano i valori essenziali dell'uomo: connessione, sensibilità, comfort e semplicità. Progettiamo per poter accogliere o essere accolti in un ambiente ospitale e rilassante, desideriamo che gli spazi riescano ad offrire ispirazione, autenticità, stimolo per la condivisione. La qualità dello spazio in cui ci troviamo influisce su ogni cosa: sul nostro umore, sulle nostre emozioni. In questo intrecciarsi di leggerezza, comfort e tecnologia. Privilegiamo sempre e comunque, l'aspetto umano anche all'interno di spazi sempre più complessi. Questo significa che gli ambienti devono essere modulari e flessibili allo stesso tempo e devono essere abbastanza intriganti, sia dal punto di vista visivo sia per l'utilizzo dei materiali, così da poter accogliere tanto il singolo quanto il gruppo.



LOUNGE AREA

“Questi spazi ibridi sono diventati ben più che semplici luoghi dove si attende: nell'era digitale, sono luoghi dove si lavora, si approfitta per una conference call o una veloce telefonata, per un caffè al volo con un amico, per un aperitivo dopo l'ufficio.”



Our collections reflect essential values of mankind: connection, sensitivity, comfort and simplicity. We plan to welcome or be welcomed in a relaxingly hospitable environment, we want spaces to succeed in offering inspiration, authenticity, stimulus for sharing. The quality of the space where we are affects everything: our mood, our emotions. In this intermingling of lightness, comfort and technology, we always prioritise the human aspect within increasingly complex spaces. This demands modularity and flexibility at the same time, for spaces to be rather intriguing, both visually as well as in terms of materials used, so as to welcome both individuals and groups.

Nos collections reflètent des valeurs essentielles de l'homme: connexion, sensibilité, confort et simplicité. Nous prévoyons d'accueillir ou être accueilli dans un environnement hospitalier et relaxant, nous voulons que les espaces offrent l'inspiration, l'authenticité, le stimulus pour le partage. La qualité de l'espace dans lequel nous nous trouvons affecte tout, notre humeur, et nos émotions. Dans cet entrelacement de légèreté, de confort et de technologie, nous privilégions toujours et en tout cas, l'aspect humain aussi dans des espaces de plus en plus complexes. Cela signifie que les environnements doivent être modulables et flexibles à la fois, ils doivent être assez intrigant, du point visuel et pour l'utilisation des matériaux, accueillir à la fois l'individu et le groupe.

“In equilibrio tra design e comfort oggi le aree lounge, le hall degli hotel, le sale d’attesa e i meeting point sono spazi soft progettati seguendo il concetto di break-out area, per rilassarci fra un impegno e l’altro: che si tratti di lavoro o di vita sociale, a volte sono più confortevoli persino del nostro salotto di casa.”

Poltrone e Divani

Soft Seating | Fauteuils et Canapés

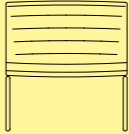
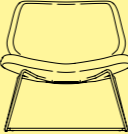
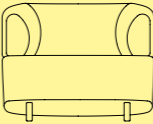
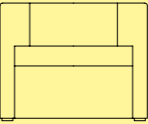
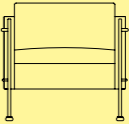
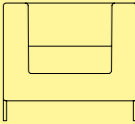
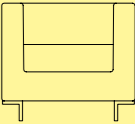
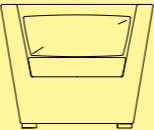
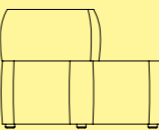
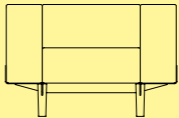
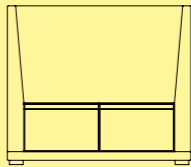
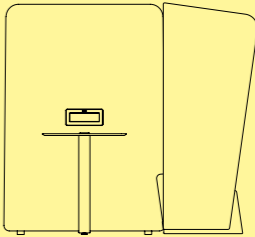
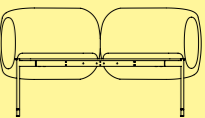
							
CIRCUIT POUF	MISS LOUNGE	EON LOUNGE	LOFT	TOFFEE	JAZZ	FRAME	HALL
15	23	31	39	49	57	65	71
							
DOUBLE	CROSS	BREAD	CIRCUIT	CIRCUIT MEDIA PRIVE & ZOOM	SNAKE		
79	87	95	107	121	137		

“Delicately balancing design and comfort, today’s lounges and lobbies, waiting and meeting points, have become soft spaces, designed along the lines of breakout areas, to welcome us in relaxation between one commitment and another: whether for work or as part of our social life, sometimes they have even become more comfortable than our own living rooms.”

“En équilibre entre design et confort aujourd’hui salons, halls d’hôtel, salle d’attente, meeting point, sont des espaces doux et conçus selon le concept pour nous accueillir en toute relaxation entre un engagement et un autre: que ce soit travail ou vie sociale, parfois ils sont encore plus confortables que notre salon à la maison.”

I **CIRCUIT POUF**, con la loro configurazione circolare, sono semplici e informali. Diverse dimensioni e altezze permettono di creare liberi giochi compositivi per molteplici soluzioni di arredo. La collezione Circuit Pouf si adatta ad ogni tipo di ambiente ma è sicuramente ideale nelle aree lounge.

CIRCUIT POUF

Diemme Lab / 2020

15

CIRCUIT POUF

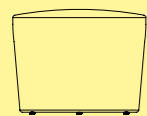

CIRCUIT POUFFES are a fun and simple way of making up playful furnishing compositions: they come in various circular shapes and sizes, allowing you to play around to create set-ups that suit your needs. They work in any kind of setting, lounge areas being an obvious application.

CIRCUIT POUFS, simples et informels, avec leur configuration circulaire. Différentes tailles et hauteurs vous permettent de composer librement, avec des jeux de composition, de nombreuses solutions d'ameublement. La collection Circuit Poufs s'adapte à tout type d'environnement mais il est certainement idéal dans les espaces lounge.

CIRCUIT POUF



Circuit Pouf soft seating / Jet 6091 - 9110 - 7025

CIRCUIT POUF

Diemme Lab / 2020



Circuit Pouf soft seating / Jet 2024 - 6091 - 9110 - 7025

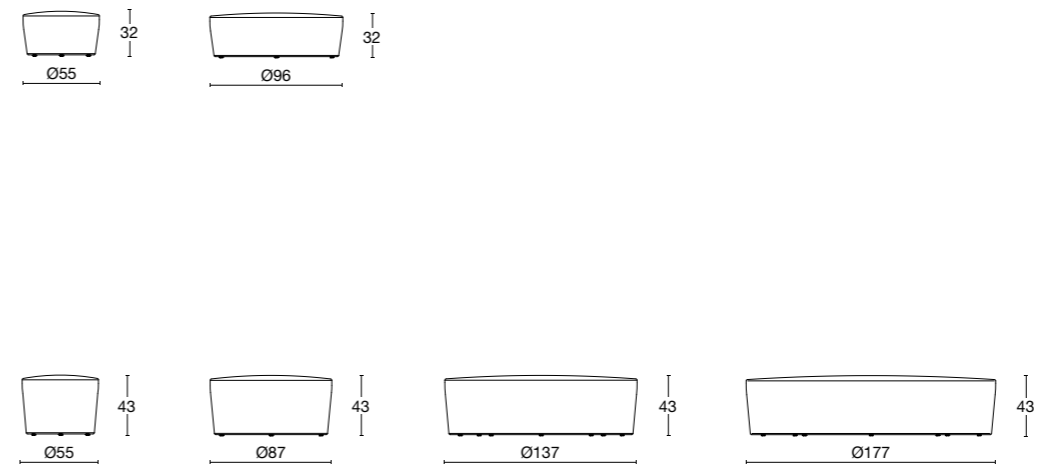

Serie di pouf di diverse dimensioni ed altezze, perfetti per arredare aree lounge e creare originali forme e dare colore agli spazi d'attesa e reception. Interni in legno e imbottitura in poliuretano espanso, su piedini in polipropilene.

Series of pouffes of different sizes and heights, perfect for furnishing lounge areas and creating original shapes and adding a splash of colour to waiting and reception areas. Wooden frame padded with foam, on polypropylene feet.

Série de poufs de différentes tailles et hauteurs, parfaits pour meubler des espaces lounge et créer des formes originales et donner de la couleur aux espaces d'attente et accueil. Structure en bois et rembourrage en mousse de polyuréthane, sur pieds en polypropylène.



struttura
legno



piedini in polipropilene



rivestimento
tessuto



pelle
ecopelle

frame
wood

polypropylene feet

upholstery
fabric

genuine leather
faux leather

structure
bois

pieds en polypropylène

revêtement
tissu

cuir
simili cuir

Nella versione poltrona,
MISS LOUNGE mantiene
il design pulito ed ergonomico
della collezione Miss.
L'ampia seduta e lo schienale
sinuoso supportano la postura
e favoriscono comfort e relax
nei momenti di pausa
e di convivialità.

MISS LOUNGE

Diemme Lab / 2015

23

MISS LOUNGE

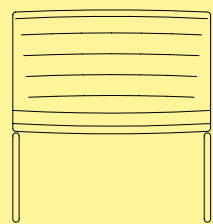

MISS LOUNGE, in its easy chair version, retains the same clean and ergonomic design of the Miss collection, with dynamic yet refined lines. The wide seat and the slinky backrest ensure posture support and promote comfort and relaxation in moments of relaxation and socializing.

MISS LOUNGE, dans la version fauteuil il garde le même design épuré et ergonomique de la collection Miss, aux lignes dynamiques et raffinées. La large assise et le dos sinueux, soutiennent la posture de la personne et favorisent le confort et la relaxation dans les moments de pause et de convivialité.

MISS LOUNGE



Miss Lounge soft seating / Planet 1304.126

MISS LOUNGE

Diemme Lab / 2015



Miss Lounge soft seating / Planet 1304.126

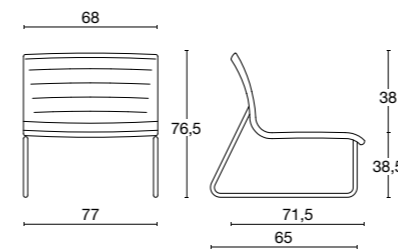

Poltrona lounge caratterizzata da una linea sinuosa ed essenziale, di spiccata versatilità, ideale per la casa, il contract e l'ufficio. La monoscocca è in multistrato di faggio, imbottita e rivestita, su base slitta bianca, nera o cromata.

Lounge chair characterized by a slinkily essential lines, by striking versatility, ideally suited to home, contract or office. The single shell is in upholstered beech plywood; white, black or chromed sled base.

Fauteuil lounge caractérisé par une ligne sinueuse et essentielle, idéal pour la maison, le contract et le bureau. La coque est en bois d' hêtre, rembourrée et recouvert sur une base traîneau blanc, noir ou chromé.



struttura

multistrato di faggio



base metallo / nero / bianco / cromato



rivestimento

tessuto



pelle
ecopelle

frame

beech plywood

metal base: black / white / chromed

upholstery

fabric

genuine leather
faux leather

structure

contreplaqué de hêtre

piètement en métal / noir / blanc / chromé

revêtement

tissu

cuir
simili cuir

Disegnata da Plus Design,
EON LOUNGE si contraddistingue
per linearità e pulizia delle forme.
La leggera incurvatura crea
un bracciolo appena accennato.
La poltroncina lounge è arricchita
da un ottomano che la trasforma
in chaise longue.
Completa la collezione il divano
dalla superficie ampia e confortevole.

EON
LOUNGE

Plus Design / 2018

31

EON LOUNGE

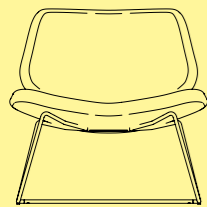

Plus Design's EON LOUNGE stands out for its clean, essential linearity. The gentle curving creates an ever so slight armrest. The lounge chair can be accompanied by its footstool to create a chaise longue, with a generously proportioned and comfortable sofa completing the collection.

Conçue par Plus Design, EON LOUNGE se démarque pour une linéarité essentielle et propre. La légère courbure crée un accoudoir légèrement tracé. Le fauteuil lounge est enrichi par un ottoman qui le transforme en chaise longue, pour compléter la collection le canapé avec une grande surface confortable.

EON LOUNGE



Eon Lounge soft seating / Gorgeous 2102 - 2111

EON LOUNGE



EON LOUNGE

Plus Design / 2018

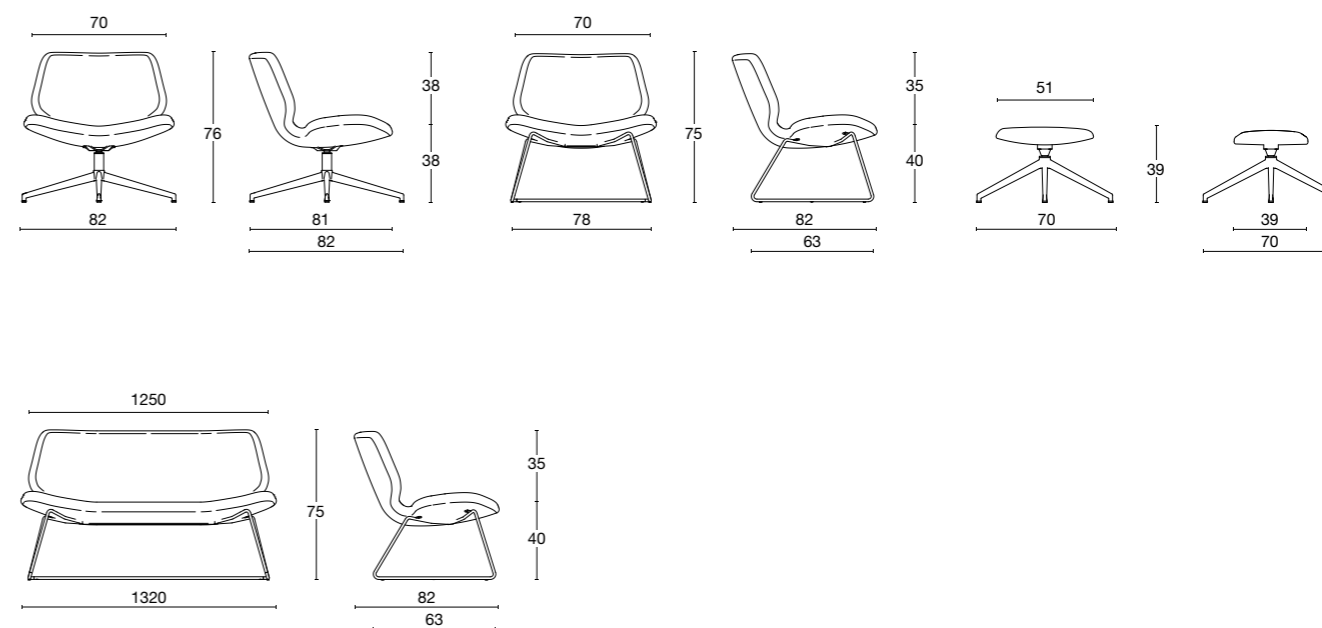

Scocca in legno curvato imbottita in poliuretano espanso e completamente rivestita. Telaio a slitta verniciato nero o telaio girevole a 4 razze in alluminio nero. Disponibile in versione poltrona, 2 posti e pouf.

Shell in curved padded wood with polyurethane foam and completely upholstered. Black lacquered sled or 4-spoked frame in black lacquered aluminum. Available as a lounge chair, two-seater, and pouffe.

Assise en bois courbé rembourrée de mousse de polyuréthane et complètement couverte. Piètement traineau peint en noir ou pivotant 4 rayons en aluminium noir. Disponible en version fauteuil, 2 places et pouf.



struttura
multistrato di faggio



base metallo nero / alluminio verniciato nero



rivestimento
tessuto



pelle
ecopelle

frame

beech plywood

base: black metal / black lacquered aluminum

upholstery

fabric

genuine leather
faux leather

structure

contreplaqué de hêtre

base en métal / aluminium peint en noir

revêtement

tissu

cuir
simili cuir

Morbida e accogliente,
dalle forme pulite e gentili,
la collezione **LOFT**
disegnata da Plus Design
si contraddistingue per l'ampio
raggio dello schienale e offre
un piacevole comfort nei momenti
di convivialità e relax.
Tra un'incurvatura e l'altra
trova spazio un dettaglio opzionale -
un tubolare metallico nero.
La scelta cromatica tra tubolare e
rivestimento è determinante
per la creazione di zone lounge
s sofisticate e originali.

LOFT

Plus Design / 2020

39

LOFT

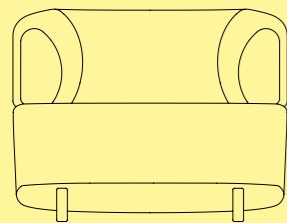

Soft and welcoming, the LOFT collection, designed by Plus Design, with clean, gentle lines, is characterized by the wide radius of its backrest which offers satisfying comfort in breakouts or relaxation. Between the two backrest curves there is space for an optional detail, a metal tube in black finish. The colour combinations between this tube and the chosen upholstery can transform lounge, waiting and lobby areas in sophisticated and original ways.

Douce et accueillante, la collection LOFT, conçue par Plus Design, aux formes épurées et douces, se caractérise par le large rayon du dossier qui offre un confort agréable dans les moments de convivialité ou de pause. Entre une courbure et l'autre du dossier, il y a un détail optionnel, un tube en métal noir. Le choix chromatique entre tubulaire et revêtement transformera les espaces lounges de manière sophistiquée et originale.



LOFT



Loft soft seating / Jet 6091

LOFT

LOFT

Plus Design / 2020

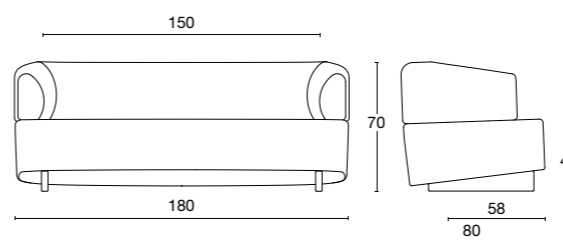
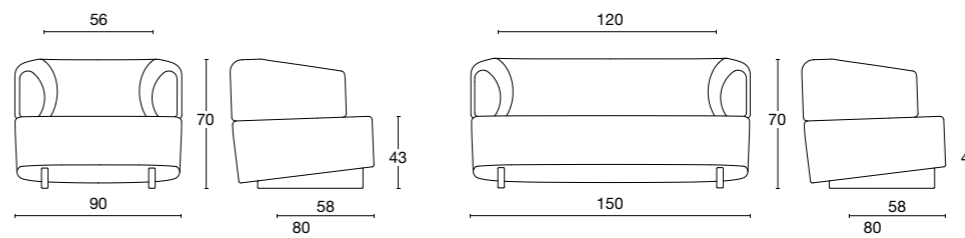

Poltrona, divano 2 e 3 posti, dalle linee sinuose ed eleganti, ideale per arredare uffici direzionali, sale d'aspetto e lounge di hotel. Struttura interna in multistrato di faggio e imbottitura in poliuretano espanso ad alta densità, su piedi in legno verniciati neri. Optional: accessorio decorativo verniciato nero tra sedile e schienale.

Armchair as well as two and three-seater sofas, with slinky, elegant lines, ideal for furnishing executive offices, waiting rooms and hotel lounges. Beech plywood frame padded with high-density polyurethane foam, on black lacquered and feature slanted wooden base. Optional: metal tube detail in black finish.

Fauteuil, canapé 2 et 3 places, aux lignes sinueuses et élégantes, idéal pour meubler les bureaux exécutifs, les salles d'attente et les lounges d'hôtel. Structure interne en contreplaqué de hêtre et rembourrage en mousse de polyuréthane haute densité, sur pieds en bois peint en noir. En option: accessoire décoratif peint en noir entre le siège et le dossier.



struttura
legno



piedi in legno verniciato nero



rivestimento
tessuto



pelle
ecopelle

frame

wood

base: black lacquered wood

upholstery

fabric

genuine leather
faux leather

structure

bois

pieds en bois peint noir

revêtement

tissu

cuir
simili cuir

La linea **TOFFEE** spicca per l'originalità delle soluzioni funzionali. L'ampia poltrona crea una sensazione avvolgente grazie alla generosa imbottitura dei braccioli, mentre il divano a seduta unica permette a più persone di prendere posto comodamente. In entrambi, la parte frontale presenta una graduale rientranza che lascia margine di libertà alla posizione delle gambe.

TOFFEE

Diemme Lab / 2008

49

TOFFEE

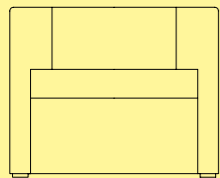

The TOFFEE collection is distinguished by the originality of its functional solutions. The wide armchair creates an enveloping feeling thanks to its generously padded armrests, whilst the single-cushioned sofa allows people to sit comfortably together. In both, the frame has a gradual angling at the front that creates a margin of freedom in terms of how you sit.

La ligne TOFFEE se démarque pour l'originalité de ses solutions fonctionnelles. Le grand fauteuil crée une sensation enveloppante grâce au rembourrage généreux des accoudoirs, tandis que le canapé, siège unique permet à plus de gens de s'asseoir confortablement. Dans les deux cas, la structure présente une échancrure progressive sur le devant qui laisse une marge de liberté à la position des jambes.



TOFFEE

TOFFEE

Diemme Lab / 2008

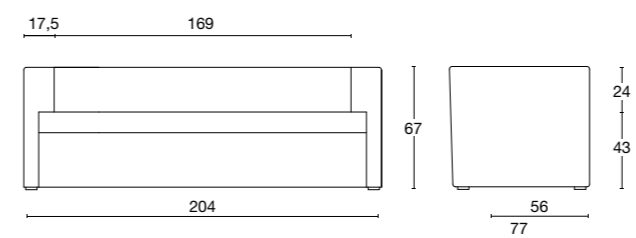
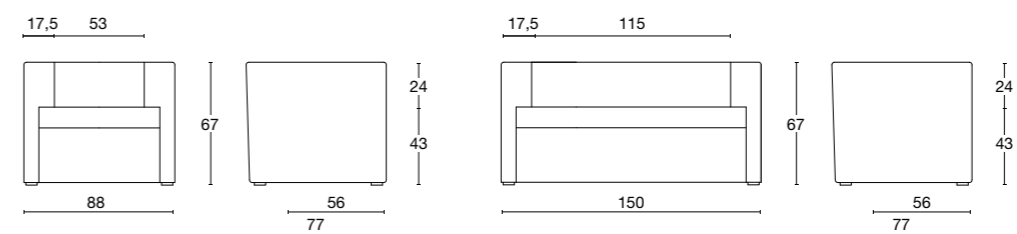

Poltrona d'attesa o divano 2 posti con struttura in multistrato di faggio, imbottitura in poliuretano espanso. Piedini in legno verniciato nero. Disponibile anche in versione 3 posti.

Waiting armchair or two-seater sofa with beech ply frame, polyurethane foam padding, fully upholstered. Black lacquered wooden feet. Three-seater sofa also available.

Fauteuil d'attente ou canapé 2 places avec structure en multipli de hêtre, rembourrage en mousse de polyuréthane. Pieds en bois peint noir. Également disponible en version 3 places.



struttura
legno



piedini legno



rivestimento
tessuto



pelle
ecopelle

frame
wood

feet: black lacquered wood

upholstery
fabric

genuine leather
faux leather

structure
bois

pieds en bois

revêtement
tissu

cuir
simili cuir

La poltrona e il divano **JAZZ**
sono l'evoluzione di
un modello classico di seduta.
Mentre gli elementi di base
sono immediatamente riconoscibili,
i particolari fanno la differenza.
La struttura portante, disponibile
in acciaio cromato oppure
di colore nero opaco, termina
con sofisticati piedini tondeggianti
che bilanciano la linearità
dell'imbottitura.

JAZZ

Diemme Lab / 2012

57

JAZZ

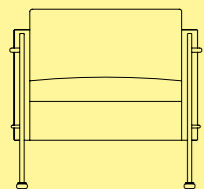
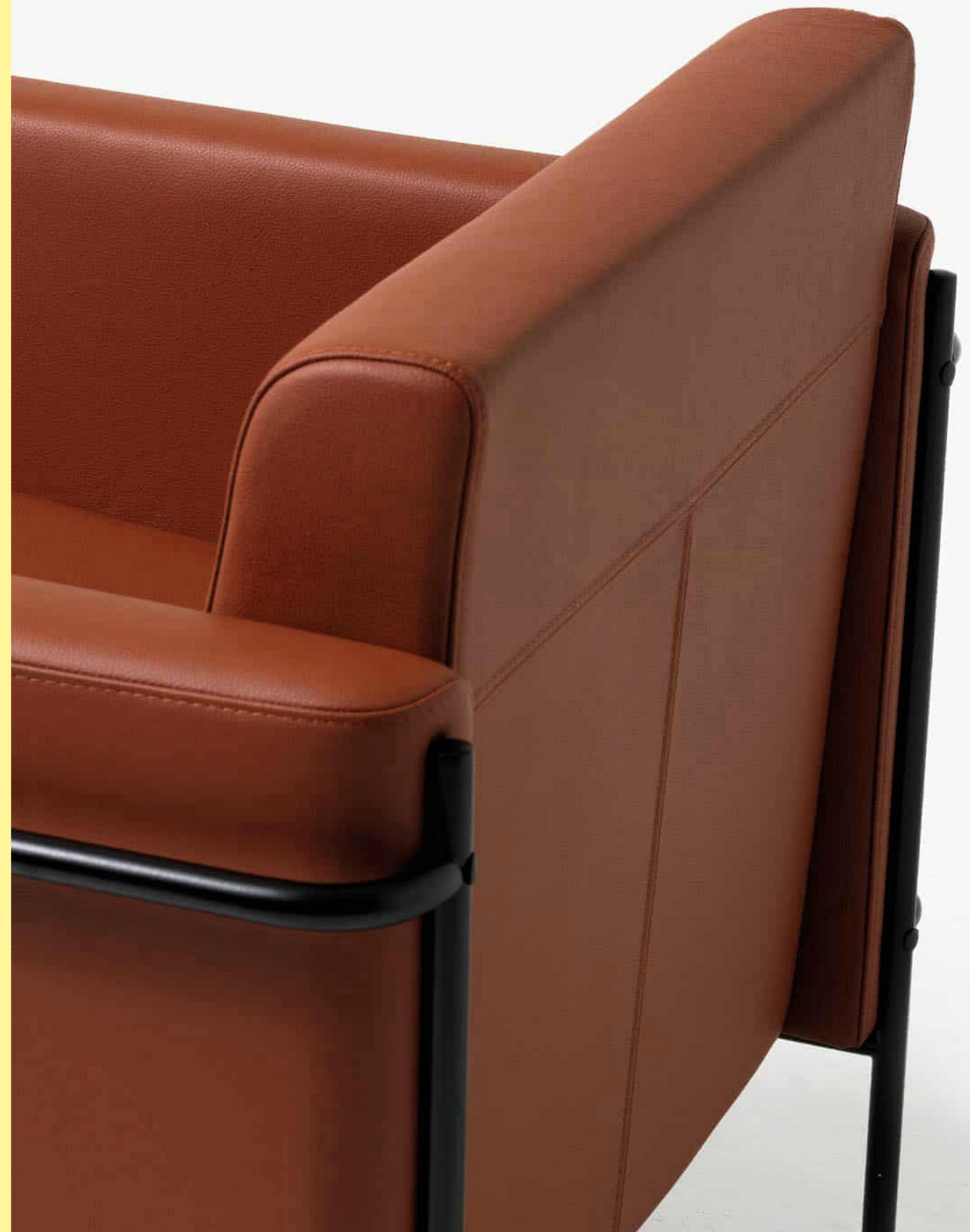

JAZZ, as an armchair and as a sofa, is the evolution of a classic seating model. Whenever the basic elements are immediately recognizable, it is the details that make all the difference. The supporting frame, available in chromed or matt black lacquered steel, has stylish rounded feet that grab the attention and balance the linearity of the of the Jazz upholstery.

JAZZ, soit le fauteuil ou le canapé, est l'évolution d'un modèle classique d'assise. Où les éléments de base sont immédiatement reconnaissables, les détails font la différence. La structure portante, disponible en acier chromé ou noir mat, se termine par des pieds arrondis sophistiqués qui attirent l'attention et équilibrent la linéarité du rembourrage du jazz.



Jazz soft seating / Fiesta 304

JAZZ

JAZZ

Diemme Lab / 2006

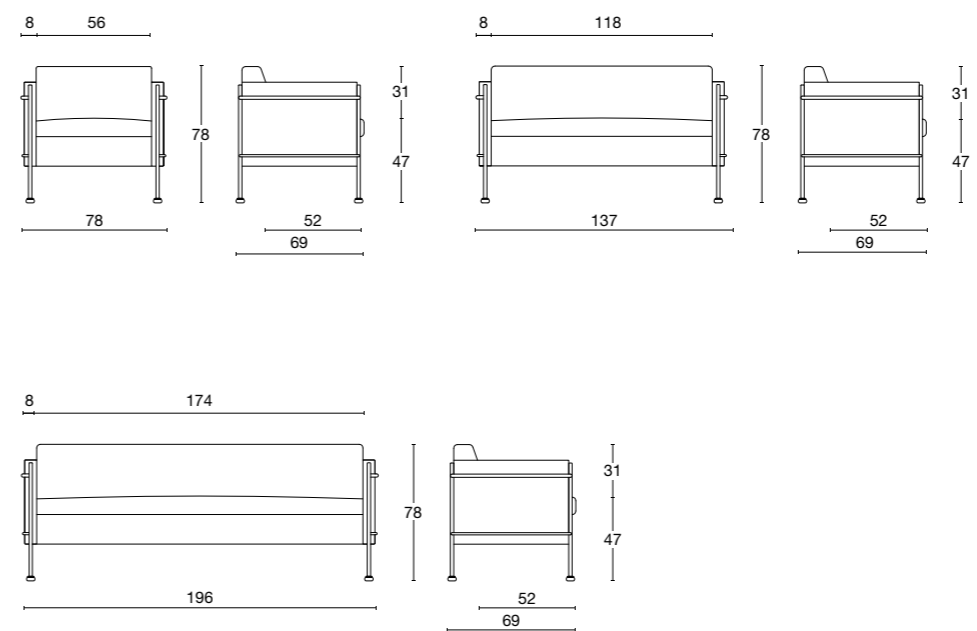

Poltrona 1 posto, divano 2 e 3 posti. Struttura in legno e acciaio cromato lucido, imbottitura in poliuretano espanso e piedini in acciaio cromato lucido o verniciato nero.

Single-seater armchair, two and three-seater sofas. Frame in wood and chromed steel, polyurethane foam padding, and chromed or black lacquered steel feet.

Fauteuil 1 place, canapé 2 et 3 places. Structure en bois et acier chromé rembourrage en mousse de polyuréthane et pieds en acier chromé poli ou peint en noir.



struttura
legno



piedini acciaio cromato lucido / verniciato nero



rivestimento
tessuto



pelle
ecopelle

frame
wood

feet: polished chrome / black lacquered steel

upholstery
fabric

genuine leather
faux leather

structure
bois

pieds en acier chromé poli / peint en noir

revêtement
tissu

cuir
simili cuir

FRAME è una seduta morbida
e piena che si inserisce perfettamente
in luoghi dall'atmosfera calda e familiare.
I braccioli stondati e l'imbottitura
generosa ingentiliscono
la sua forma cubica.
Anche nella versione divano,
Frame conserva la propria
struttura razionale ma crea
uno spazio intimo e confortevole.

FRAME

Diemme Lab / 2012

65

FRAME

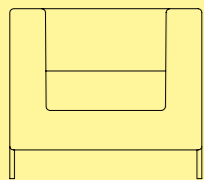

FRAME is soft and generously proportioned, fitting perfectly into places with a warm and friendly atmosphere. Its rounded armrests and ample upholstery soften its cubic shape, which is otherwise precise in its geometry thanks to its flat surfaces and cornering. Also in its sofa version Frame retains its own rational structure but creates an intimate and comfortable space.

FRAME est une famille de canapés doux qui s'adapte parfaitement dans des endroits à l'atmosphère chaleureuse et familière. Accoudoirs et rembourrage arrondis adoucissent généreusement sa forme cubique, autrement précis dans les géométries grâce à des surfaces planes et des angles vifs. Également dans la version canapé, Frame conserve sa propre structure rationnelle mais crée un espace intime et confortable.

FRAME

Diemme Lab / 2012



Frame soft seating / Gorgeous 2113

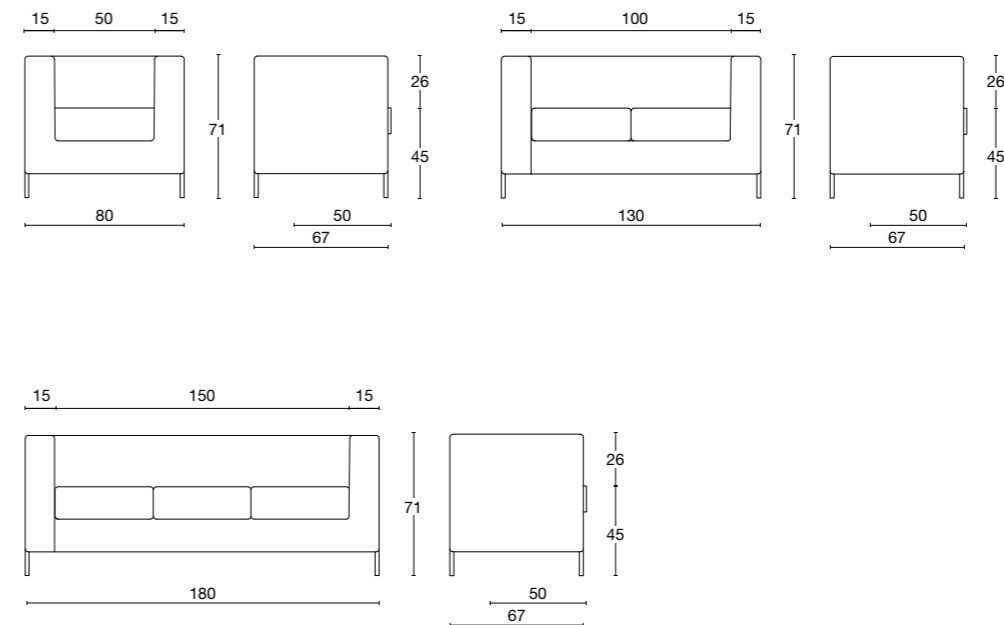

Poltrona, divano 2 e 3 posti, con struttura in multistrato di faggio, imbottitura in poliuretano espanso ad alta densità. Piedini in alluminio.

Armchair, two and three-seater sofa, with beech ply frame, high density polyurethane foam padding. Aluminum feet.

Fauteuil, canapé 2 et 3 places, avec structure en multiplis de hêtre, rembourrage en mousse de polyuréthane haute densité. Pieds en aluminium.



struttura
legno



piedini alluminio



rivestimento
tessuto



pelle
ecopelle

frame
wood

feet: aluminium

upholstery
fabric

genuine leather
faux leather

structure
bois

pieds en aluminium

revêtement
tissu

cuir
simili cuir

Il rigore della poltrona **HALL**
è bilanciato dai suoi dettagli originali.
L'opzionale glifo a rombo della trapunta
decora con eleganza lo schienale.
La base è sostenuta dai particolari
piedini ad angolo, la cui geometria
dona modernità alla seduta.
È proprio questa cura per i particolari
a rendere Hall una seduta ideale
per ambienti tradizionali
alla ricerca di elementi
di design contemporaneo.

HALL

Diemme Lab / 2015

71

HALL

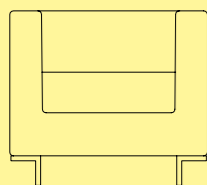

The rigour of HALL is balanced by its original detailing. Optional diamond quilting elegantly enhances the backrest, while the base has feature corner feet that create the collection's modern geometry. It is precisely this attention to detail that makes Hall ideal for traditional settings that nevertheless require a touch of contemporary design.

La rigueur de HALL est l'équilibré par des détails originaux. Le glyphe losange facultatif décore avec élégance le dossier, tandis que la base est prise en charge avec des pieds d'angle particuliers dont la géométrie donne modernité au siège. C'est précisément cette attention au détail qui fait de Hall une assise idéale pour les environnements de goût traditionnel mais ils recherchent des éléments du design contemporain.



HALL

HALL

Diemme Lab / 2015

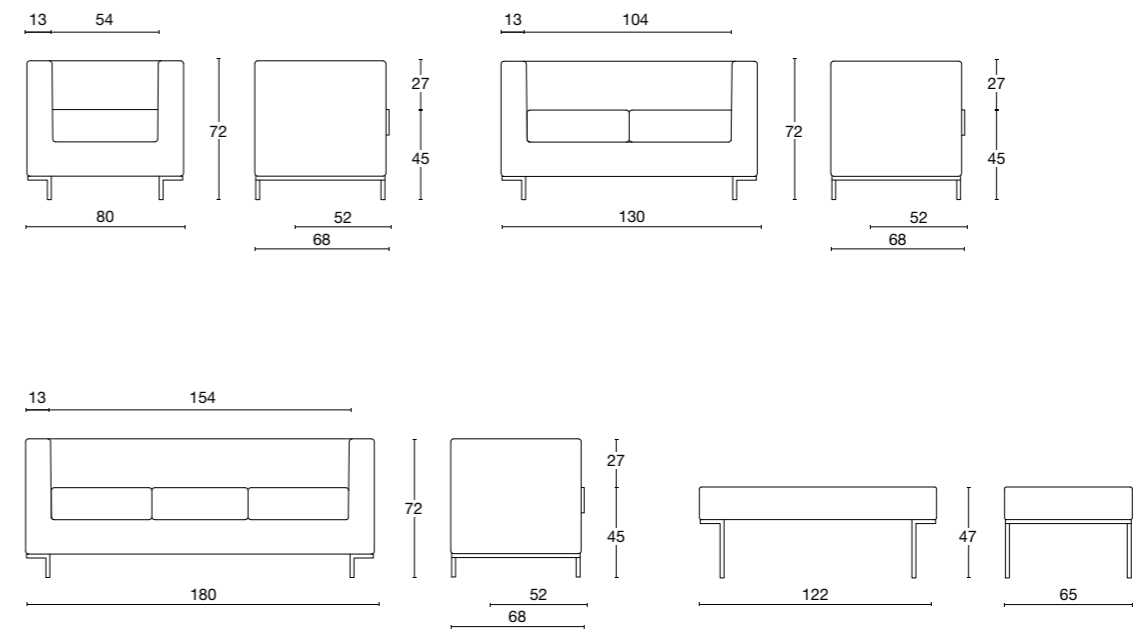

Poltrona, divano 2 e 3 posti, con struttura in multistrato di faggio, imbottitura in poliuretano espanso ad alta densità. Piedini in acciaio verniciati antracite. Disponibile anche in versione panca 2 posti.

Armchair, two and three-seater sofa, or bench version, with beech ply frame, upholstered with high density polyurethane foam. Dark grey lacquered steel feet.

Fauteuil, canapé 2 et 3 places, ou version banc, avec structure en multiplis de hêtre, rembourrage en mousse de polyuréthane haute densité. Pieds en acier antracite peint.



struttura
legno



piedini acciaio verniciato antracite



rivestimento
tessuto



pelle
ecopelle

frame
wood

feet: dark grey lacquered

upholstery
fabric

genuine leather
faux leather

structure
bois

pieds en acier peint antracite

revêtement
tissu

cuir
simili cuir

Il sistema **DOUBLE** esprime
il concetto di modularità
in una nuova prospettiva.
La collezione, caratterizzata
da un design angolare,
è disponibile in tre versioni:
poltrona concava e convessa,
e divano. Se accostati, gli elementi
danno vita a un dinamico
gioco di diagonali.

DOUBLE

Diemme Lab / 2007

79

DOUBLE

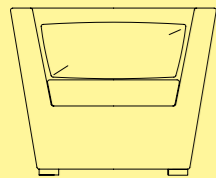

The DOUBLE system sets the whole concept of modularity in a new perspective. Double armchairs, characterized by their distinctive linear design, come in two versions: one open, flaring outwards, the other closed and more contained. There is also a sofa that interlocks with the closed armchair. If combined, these pieces can create a dynamic game of diagonals that runs from the feet right up to the armrests.

Le système DOUBLE pose le concept de modularité dans une nouvelle perspective. Fauteuils Double, caractérisés par une conception linéaire distinctifs, ils ont deux versions: une ouverte, tournée vers l'extérieur, et une fermée, plus contenue. Vous pouvez ajouter aussi le canapé à côté du fauteuil fermé. S'ils sont combinés, ces éléments créent un jeu dynamique des diagonales qui partent des pieds aux accoudoirs.

DOUBLE



DOUBLE

Diemme Lab / 2007



Double soft seating / Era CSE11 - CSE13

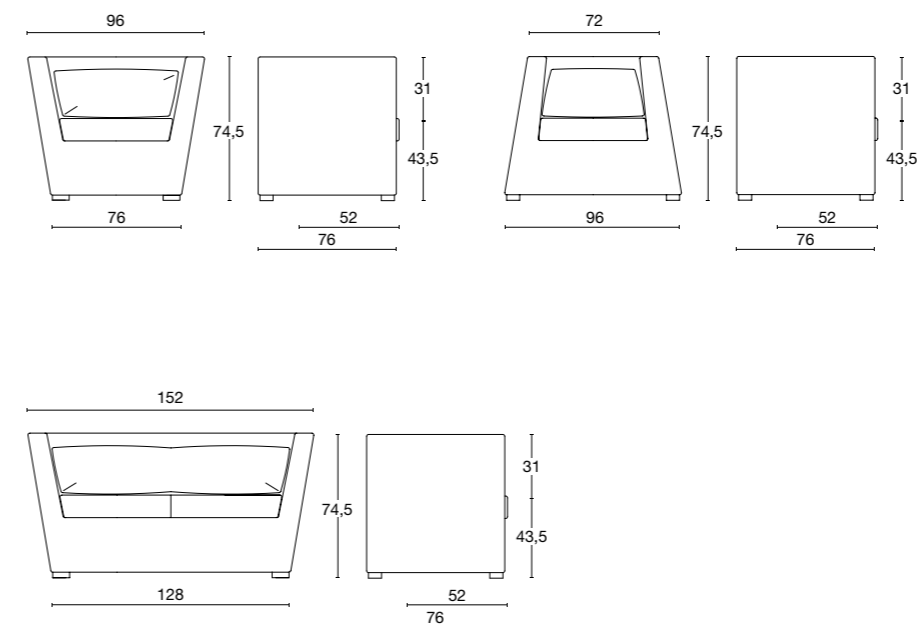

Poltrone dalla forma elegante, caratterizzate da una perfetta linea di aderenza per l'accostamento l'una con l'altra. Con struttura in multistrato di legno imbottito in poliuretano espanso. Piedini in alluminio lucido. Disponibile anche divanetto 2 posti.

Armchairs with an elegant shape, perfectly designed to interlock snugly. With a plywood frame and upholstered with polyurethane foam. Polished aluminum feet. Two-seater sofa also available.

Fauteuils de forme élégante, caractérisés par une ligne parfaite de l'adhésion à l'approche les uns aux autres. Structure en multiplis de bois rembourré de mousse de polyuréthane. Pieds en aluminium poli. Canapé 2 places également disponible.



struttura
legno



piedini alluminio lucido



rivestimento
tessuto



pelle
ecopelle

frame
wood

feet: polished aluminum

upholstery
fabric

genuine leather
faux leather

structure
bois

pieds en aluminium poli

revêtement
tissu

cuir
simili cuir

Strutturata come elementi individuali tondeggianti, **CROSS** è una collezione modulare divertente e confortevole. La sua personalità si esprime con composizioni peculiari e inedite. Il suo aspetto singolare può essere rafforzato da particolari rivestimenti disponibili per la base pouf e per lo schienale.

CROSS

Diemme Lab / 2010

87

CROSS

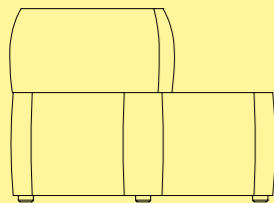

Made up of individual rounded blocks rounded, with curved corners, CROSS is a funky, comfy modular collection. It only has a handful of units, but it has the potential to be configured into unusual and never before seen constellations. Its striking effect can be heightened by the selecting special upholsteries for the pouffe base and backrest.

Structuré en blocs individuels arrondis, CROSS est une collection modulaire amusante et confortable. Il n'est composé que de quelques éléments, mais il a le potentiel à moduler en constellation de solutions insolites. Son effet singulier peut être renforcé par les détails de revêtements disponibles pour la base et le dossier.



Cross soft seating / Wolin 7050.36 - 7050.22 - 7050.31

CROSS

CROSS

Diemme Lab / 2010

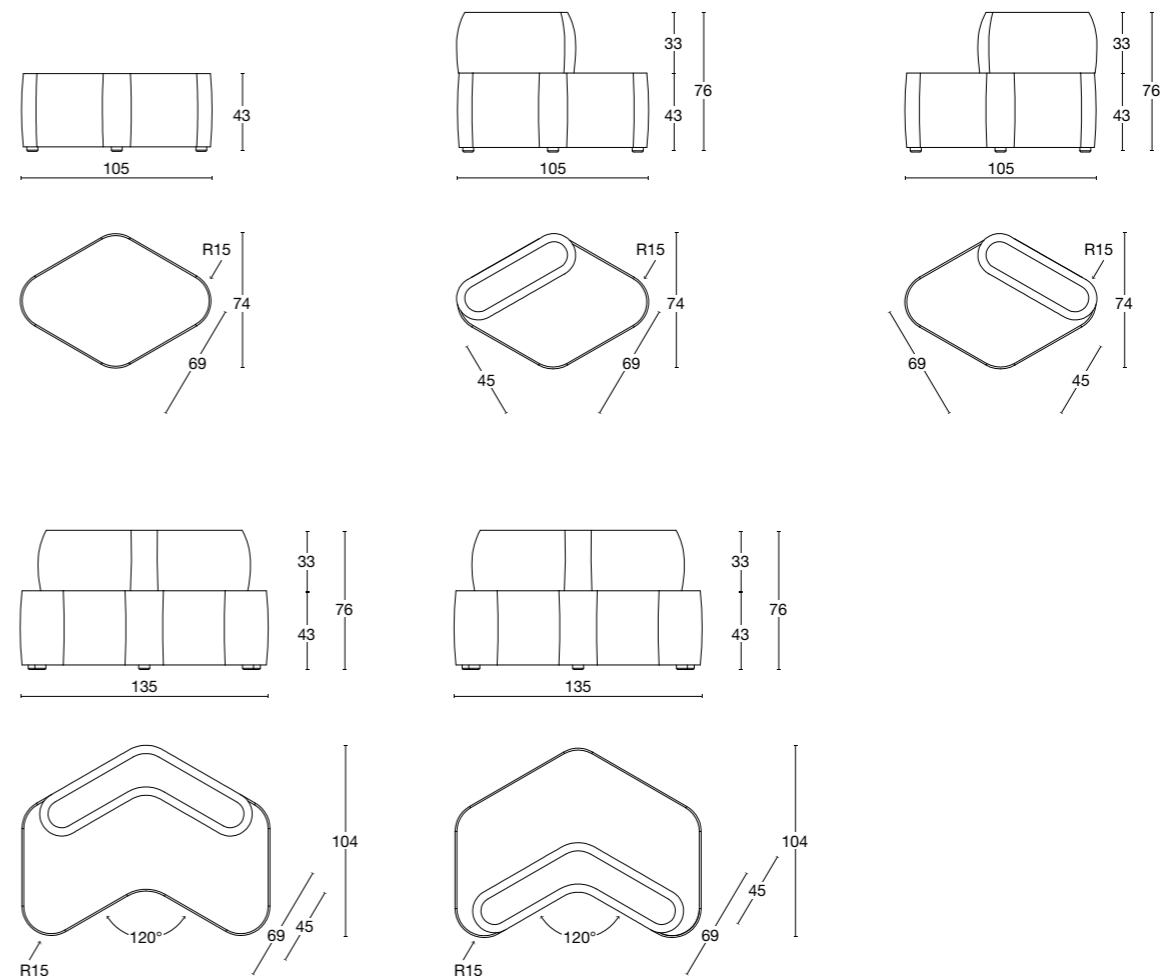

Divano componibile, dalla forma elegante e originale. Struttura interna in legno e imbottitura in poliuretano espanso ad alta densità. Piedini in polipropilene nero.

Elegant and original modular sofas. Wooden frame upholstered with high-density polyurethane foam. Black polypropylene feet.

Canapé modulable, avec une forme élégante et originale. Structure interne en bois et rembourrage en mousse de polyuréthane haute densité. Pieds en polypropylène noir.



struttura
legno



piedini in polipropilene nero



rivestimento
tessuto



pelle
ecopelle

frame
wood

feet: black polypropylene

upholstery
fabric

genuine leather
faux leather

structure
bois

pieds en polypropylène noir

revêtement
tissu

cuir
simili cuir

BREAD è un sistema di divani,
poltrone e chaise longue.
Gli elementi possono essere accostati
per rispondere a particolari
esigenze di comfort e fruizione,
diverse per ogni tipo di ambiente.
Bread afferma la propria identità
nei suoi dettagli: i piedini in legno
di rovere e la sottile lastra metallica
che delimita il fianco.

BREAD

DorigoDesign / 2015

95

BREAD

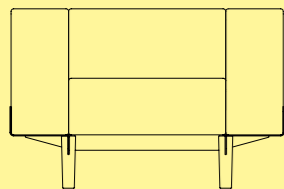

BREAD is a system of sofas, armchairs and chaise longues. Each single piece can be placed alongside others to meet the needs for comfort and use that arise from settings with different functions, from offices to waiting areas. Bread asserts its identity through its detailing: its oak feet, and the thin metal plate at the side that encases the whole.

BREAD est un système de canapés, fauteuils et chaise longue. Chaque pièce peut être assemblée à d'autres pour répondre aux besoins de confort et d'utilisation qui proviennent des environnements avec différentes fonctions, pour bureaux ou salles d'attente. Bread affirme son identité dans ses détails: les pieds en bois chêne et la fine plaque métallique qui délimite le côté de tous les composants.

Modular Sofas

BREAD è un sistema modulare composto da poltrone, divani, chaise longue, pouf, e da un'ampia serie di elementi: centrali, angolari, terminali, rettangolari, e quadrati, che possono essere combinati tra loro in vari modi. È così possibile creare e strutturare una zona relax particolare e unica. Può essere configurato in modo semplice o articolato a seconda dell'identità e della dimensione dello spazio.

BREAD is a modular system comprising armchairs, sofas and a wide range of elements: chaise-longue, central, corners, pouffes, terminals, oblongs and squares that can be combined together in various configurations. In this way it is possible to create and structure a uniquely striking relaxation area, which can be set up complexly or simply according to the function and size of the available space.

BREAD est un système modulaire composé de fauteuils, canapés et une large gamme d'éléments: chaise longue, centraux, angles, poufs, rectangulaires, carrés qui peuvent être combinés entre eux de diverses manières. De cette façon, il est possible de créer et de structurer un espace de détente particulier et unique, il peut être configuré de manière plus complexe ou simple selon l'identité et la disponibilité de l'espace.

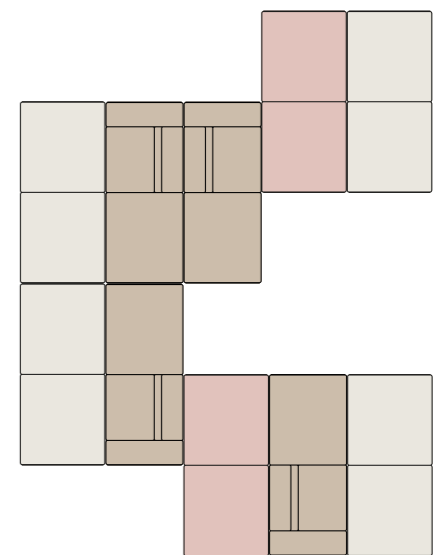
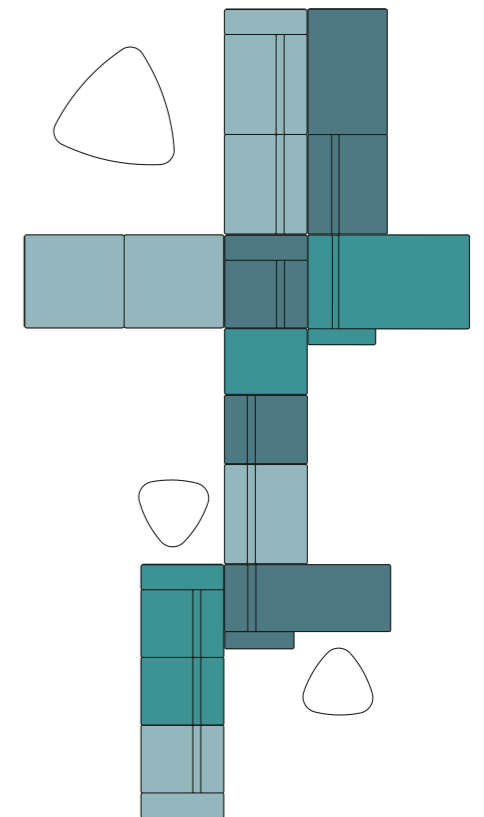
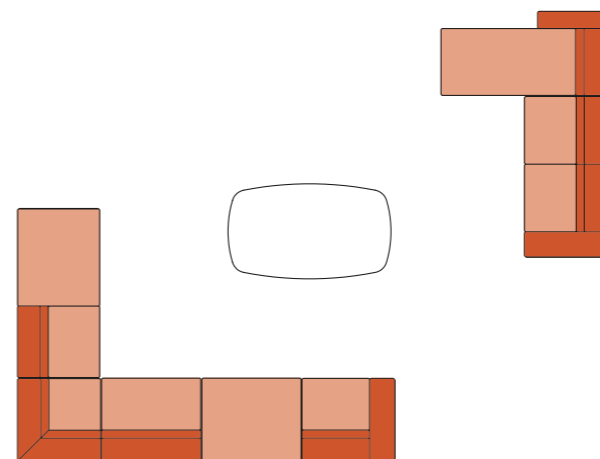
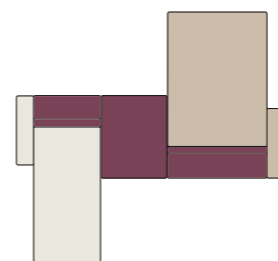
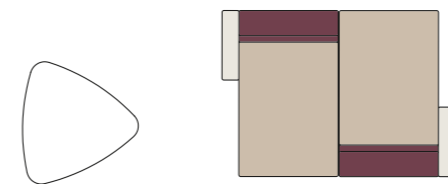
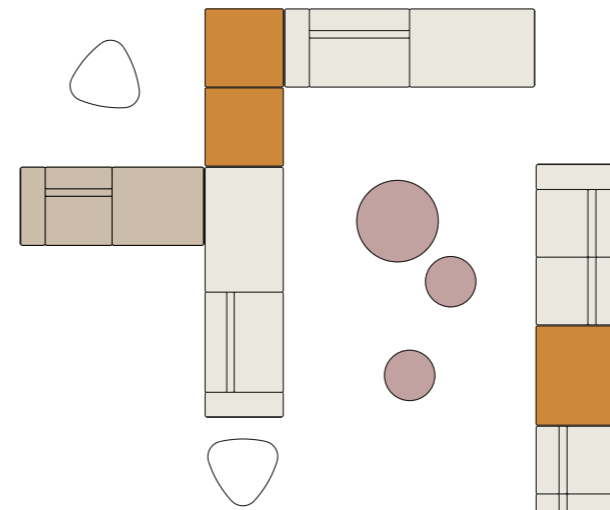

BREAD

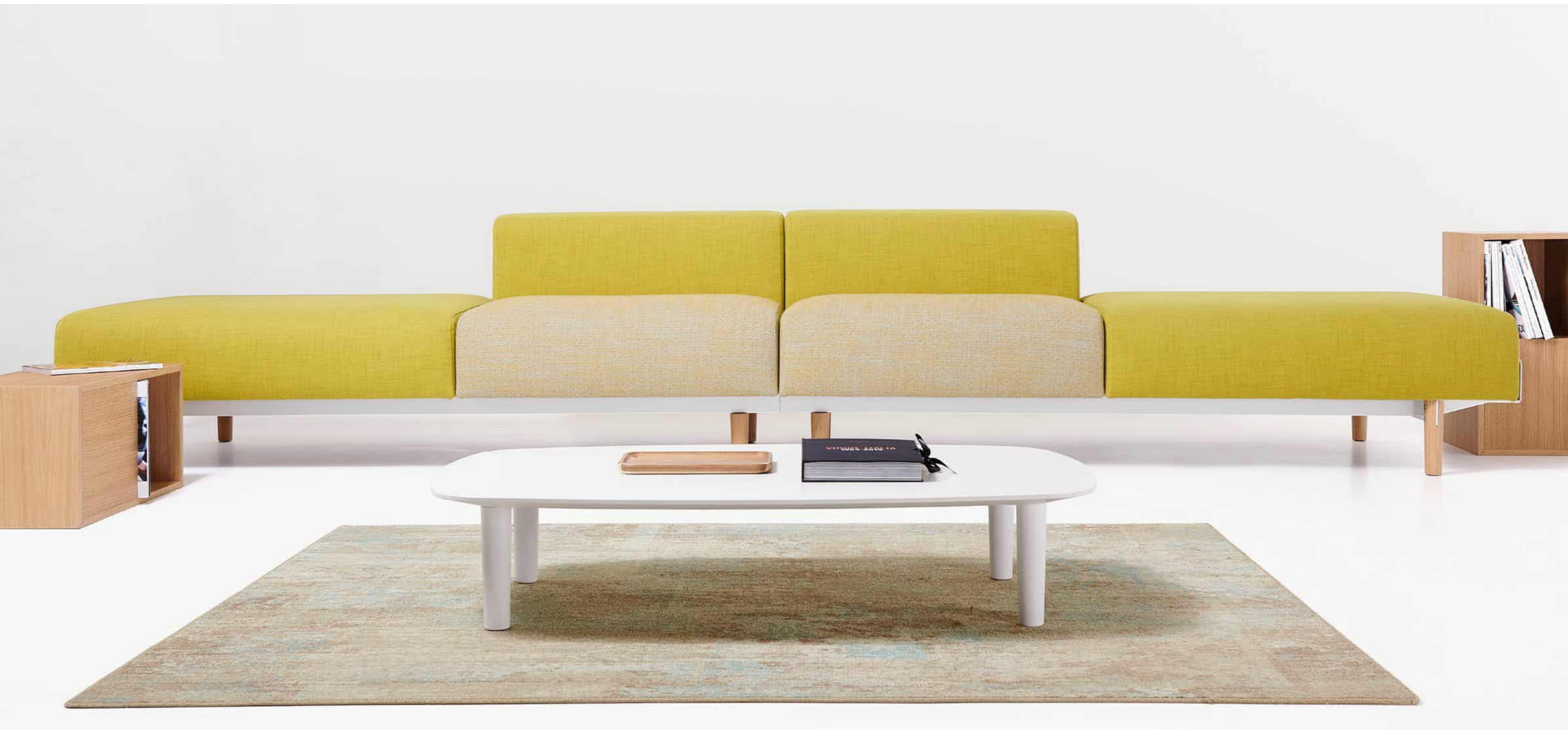

Bread soft seating / Wolin 7050.43 - Hestan 7035.19

BREAD



Bread soft seating / Era CSE01



BREAD



BREAD

DorigoDesign / 2015

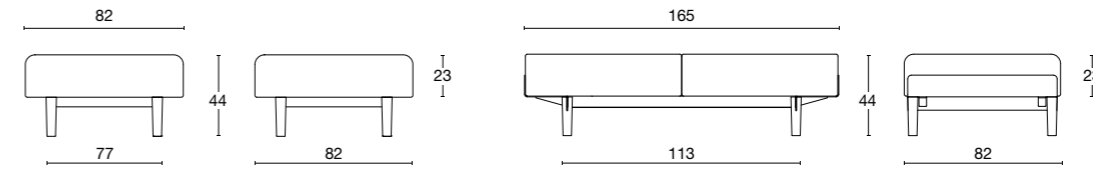

3 P bench / L. 225

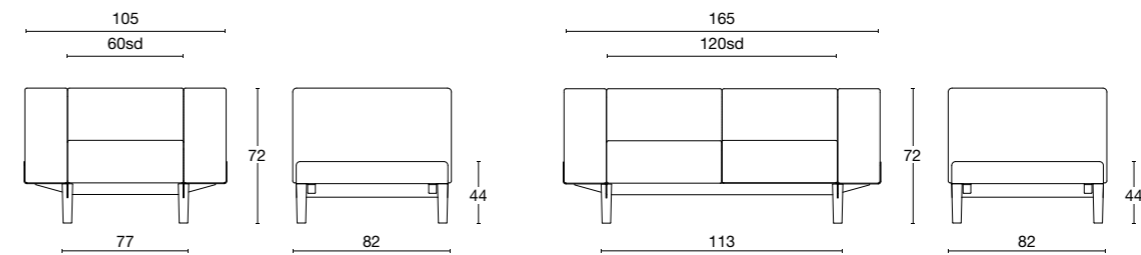

3 P sofà / L. 225

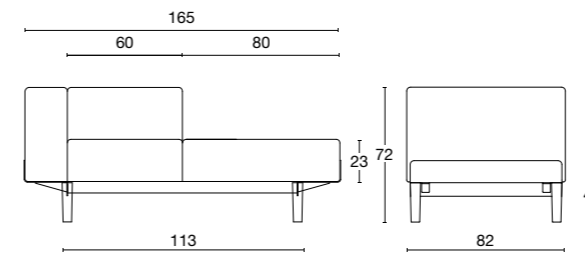

3 P island / L. 225

Poltrona e divano modulare a 2 e 3 posti, e disponibile in una serie di elementi adatti anche per composizioni di diversa forma, interni in legno e imbottitura in poliuretano espanso. Struttura in acciaio verniciato bianco e piedini in rovere.

Armchair and modular two and three-seater sofas, available in a series of elements also suitable for making up different shapes, with wood and polyurethane foam interior.

Fauteuil et canapé modulaire avec 2 et 3 sièges, et disponible dans une série d'éléments également adaptés aux compositions de différentes formes, intérieurs en bois etrembourrage en mousse de polyuréthane. Structure en acier peint en blanc et pieds en chêne.



struttura
legno



piedini in rovere



rivestimento
tessuto



pelle
ecopelle

frame
wood

feet: oak

upholstery
fabric

genuine leather
faux leather

structure
bois

pieds en chêne

revêtement
tissu

cuir
simili cuir

Disegnata da DorigoDesign,
CIRCUIT è una collezione modulare
unica nella sua versatilità.
Soluzione tecnica d'avanguardia,
è in grado di plasmarsi con duttilità
all'ambiente in cui è inserita.
Assume forme sia rettilinee
che tondeggianti, e può essere
dotata di tavoletta incorporata
e di porte USB.
Sviluppa un gioco dinamico
di pieni e vuoti tra imbottitura
e braccioli.

CIRCUIT

DorigoDesign / 2013

107

CIRCUIT

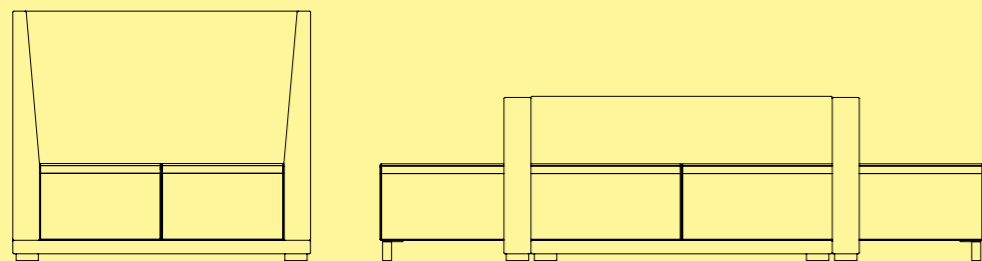

Design by DorigoDesign CIRCUIT is a modular collection, unique in its versatility. It is a cutting-edge technical solution, able to shape itself with absolute fluidity to the environment for which it is chosen, taking on either straight or curved forms, and it can be equipped with a built-in writing tablet and USB ports. It develops into a dynamic game of full and empty spaces between the upholstery and the armrests.

CIRCUIT solution modulaire unique dans sa polyvalence. C'est une solution technique, capable de se modeler avec une ductilité absolue à l'environnement dans lequel il est inséré et prend des formes à la fois droites et arrondies, et peut être équipé d'une tablette ports USB et intégrés. Il évolue dans un jeu dynamique espaces pleins et vides entre le rembourrage et accoudoirs.

Modular Seating

CIRCUIT è un sistema di sedute altamente modulare, versatile e creativo. Permette di personalizzare gli spazi creando ambienti di attesa, aree per incontri informali e meeting, o nicchie dove poter lavorare e confrontarsi.

È prevista la versione panca oppure la possibilità di scegliere tra due diverse altezze di schienale, quello alto perfetto per creare "salottini" e aree meeting dove la privacy è importante.

I braccioli con la possibilità di elettrificazione rendono le sedute tecnologiche ed interattive, perfette per le situazioni moderne di attesa e lounge. Completano la collezione i pouf, da utilizzare come punti di seduta o appoggio, e una linea di tavolini.

Tutti gli elementi possono essere combinati in vari modi per creare e strutturare una zona relax particolare e unica.

CIRCUIT is an extremely modular and versatile seating system. It is innovative and creative, allowing you to customize spaces by creating waiting and informal meeting areas, niches where to work and catch up. There is a bench version, as well as the choice of two different back heights, the higher being perfect to create "parlours" and meeting areas where privacy is important. The armrests can have electric power points making this collection technological and interactive, perfect for modern lounge and waiting situations. Pouffes complete the collection whether used as a perch or for regular sitting, along with a series of tables. Sofas, chaise-longues, central and corner units, pouffes, terminals, oblongs and squares can all be combined with each other in various ways, so as to create and structure a particular and unique relaxation area.

CIRCUIT est un système d'assise hautement modulaire et polyvalent, innovant et créatif, il vous permet de personnaliser les espaces en créant salles d'attente, espaces pour réunions et rassemblements informels, niches où travailler et comparer. Il y a la version banc, ou la possibilité de choisir entre deux hauteurs de dossier différentes c'est parfait pour créer "Salons" et espaces de réunion où l'intimité est importante. Les accoudoirs avec possibilité d'électrification ils rendent technologiques, les assise et interactifs, parfaits pour les situations de salon et d'attente moderne. La collection de poufs à utiliser comme points d'assise complète la collection et aussi une ligne de tableaux. Canapés, chaises longues, central, angles, terminaux, rectangulaires, carrés peuvent être combinés les uns avec les autres de différentes manières, de cette façon, vous pouvez créer et structurer un espace de détente particulier et unique.

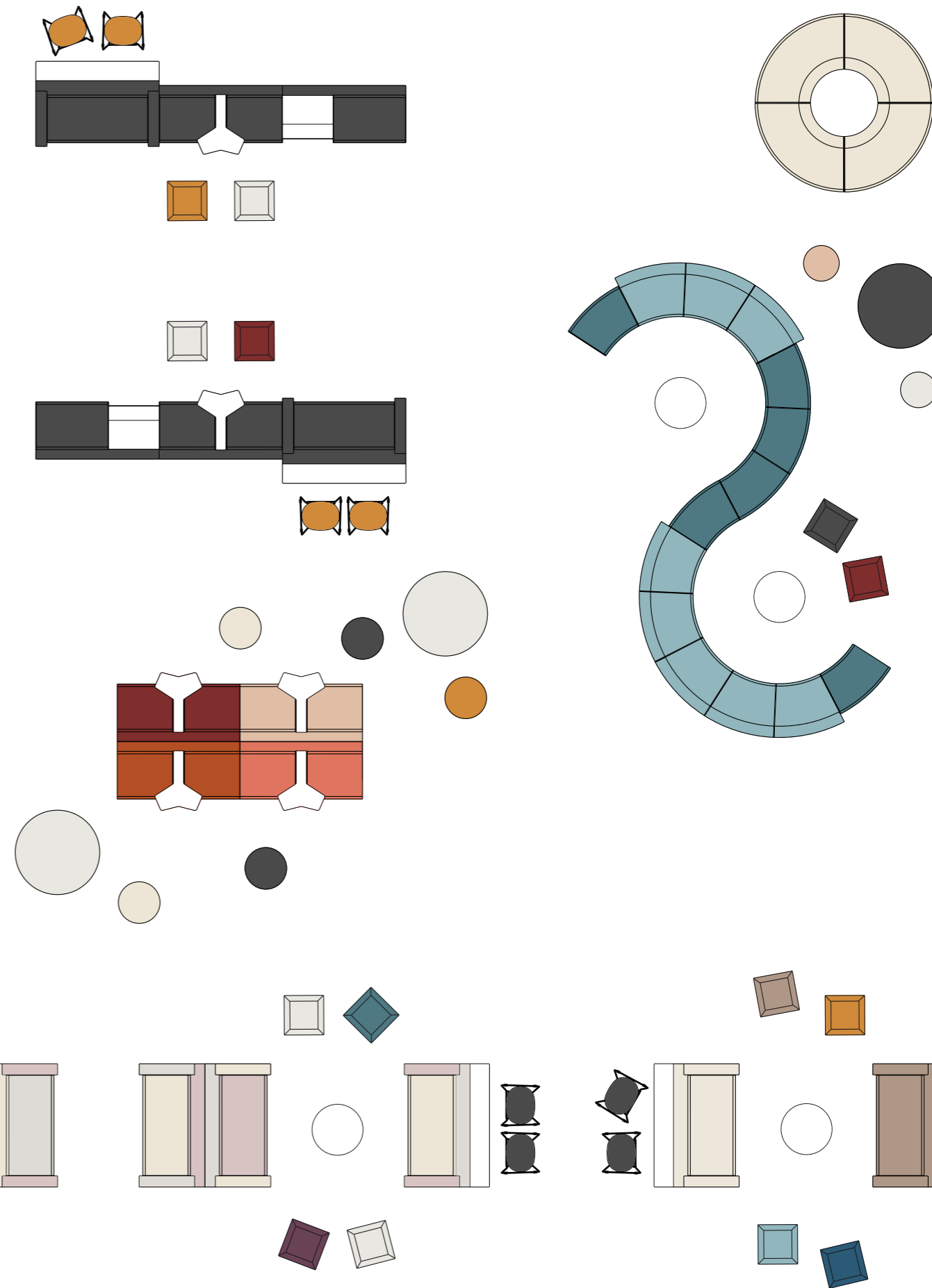

CIRCUIT



Circuit soft seating / Era CSE01 / Jet 9110

CIRCUIT



Circuit soft seating / Era CSE01 / Jet 9110

CIRCUIT



Circuit soft seating / Wolin 7050.22

CIRCUIT

DorigoDesign / 2013



Circuit soft seating / Wolin 7050.22

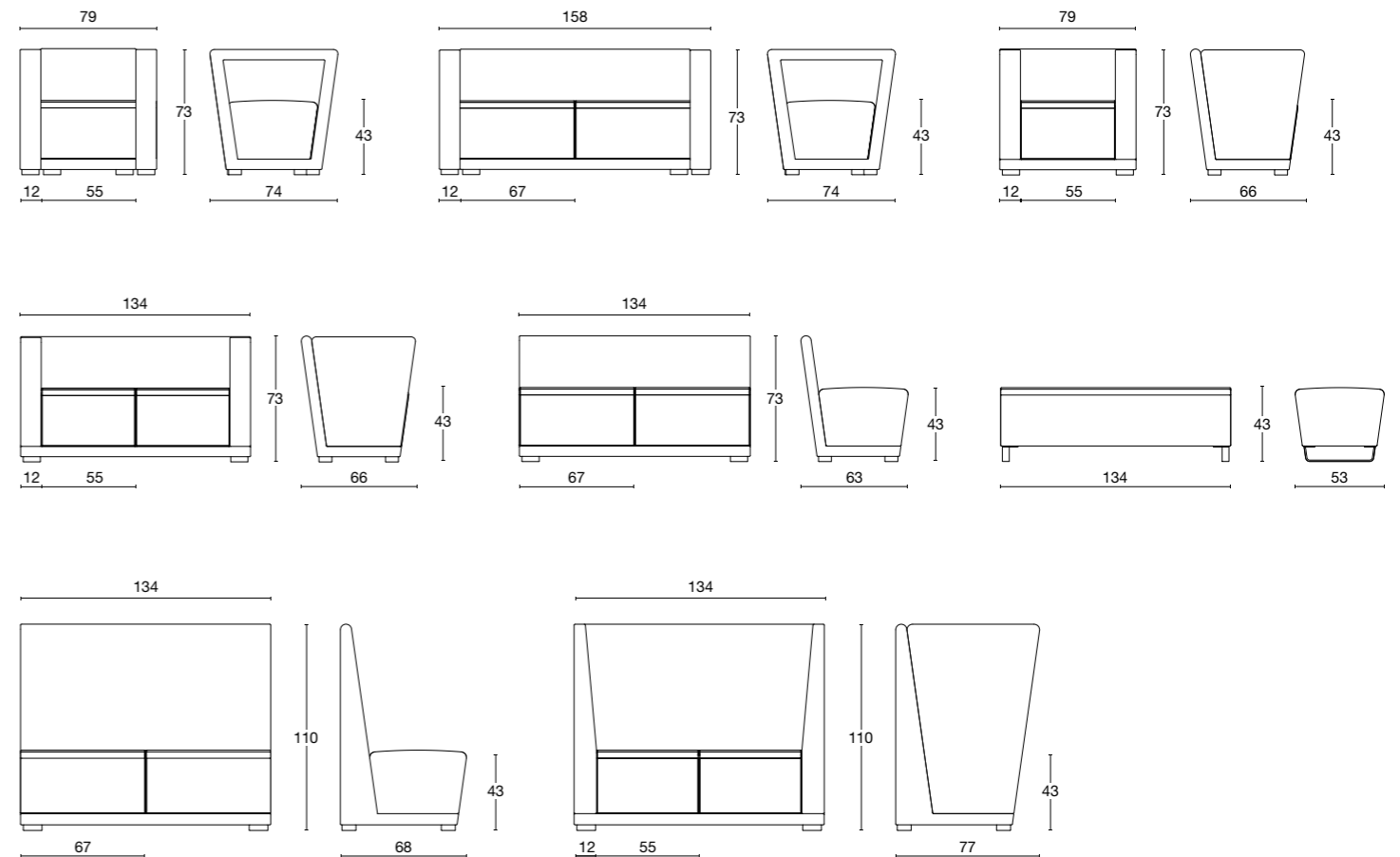

Un concetto dalle infinite possibilità. Interni in legno e imbottitura in poliuretano espanso. Comprende la poltrona, il divano due posti e una serie di elementi di varie dimensioni e altezze, lineari o curvi, che uniti tra loro formano composizioni originali adatte ad ogni tipo di spazio e layout.

A concept with infinite possibilities. Wood and polyurethane foam interiors. Includes armchair, two-seater sofa, and a series of elements of various sizes and heights, straight or curved, which can be joined together to form original compositions suitable for any type of space and layout. Polyurethane foam padding and wooden feet.

Un concept aux possibilités infinies. Intérieur en bois et rembourrage en mousse de polyuréthane. Comprend un fauteuil, un canapé deux places et un série d'éléments de différentes tailles et hauteurs, linéaires ou courbes, réunis ils forment des compositions originales adaptées à tout type d'espace disposition. Rembourrage en mousse de polyuréthane et pieds en bois.



struttura
legno



piedi in legno verniciati antracite



rivestimento
tessuto



pelle
ecopelle

frame
wood

feet: dark grey lacquered wood

upholstery
fabric

genuine leather
faux leather

structure
bois

pieds en bois peint anthracite

revêtement
tissu

cuir
simili cuir

CIRCUIT MEDIA è un elemento complementare alla serie **CIRCUIT PRIVÈ**, una seduta la cui struttura favorisce la privacy. Circuit Media è provvisto di rotelline per un facile spostamento ed è composto da due elementi: un piano lavoro e un pannello, dotato di porte USB e predisposizione monitor. Completa la collezione **CIRCUIT ZOOM**, che se abbinato alla seduta Circuit Privè crea nuovi spazi per video-call e diventa un'area operativa privata e confortevole. Combinati al resto della collezione Circuit, arredano gli spazi creando nuove aree lavoro.

CIRCUIT MEDIA / PRIVÈ ZOOM

Diemme Lab / 2018 / 2020

121

CIRCUIT MEDIA & PRIVÉ

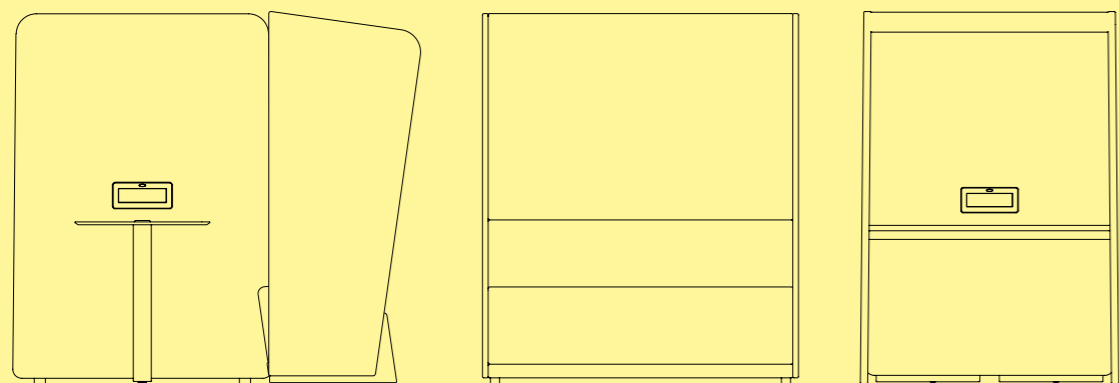

CIRCUIT MEDIA is an complementary piece to the CIRCUIT PRIVÉ seating series, which has enclosed sides and roof to assure privacy. Circuit Media, on wheels for easy movement, is made up of two elements: a worktop, and a panel equipped with USB ports and designed to hold a TV screen. Completing the collection is CIRCUIT ZOOM, which, if combined the Circuit Privé seating unit, creates new spaces for video conferencing and becomes a private and comfortable work area. Combined with the rest of the Circuit collection, these fit out spaces to create new work areas.

CIRCUIT MEDIA est un élément complémentaire à la série CIRCUIT PRIVÉ, un canapé par la structure délimitée qui favorise l'intimité. Circuit Media, est aussi fourni avec des roulettes pour un déplacement facile, il est composé de deux éléments: un plan de travail, un panneau équipé de ports USB et préparé pour les écrans de télévision. Complète la collection CIRCUIT ZOOM, que, si combiné avec le siège du Circuit Privé, crée des nouveaux espaces par appel vidéo et devient une zone opérationnelle privé et confortable. Combiné avec le reste de la collection Circuit, décore les espaces en créant des nouveaux espaces travail.



CIRCUIT PRIVÈ & MEDIA



CIRCUIT MEDIA & PRIVÈ



Circuit Media soft seating / Jet 3090

CIRCUIT PRIVÈ



CIRCUIT MEDIA & PRIVÈ

Diemme Lab / 2018

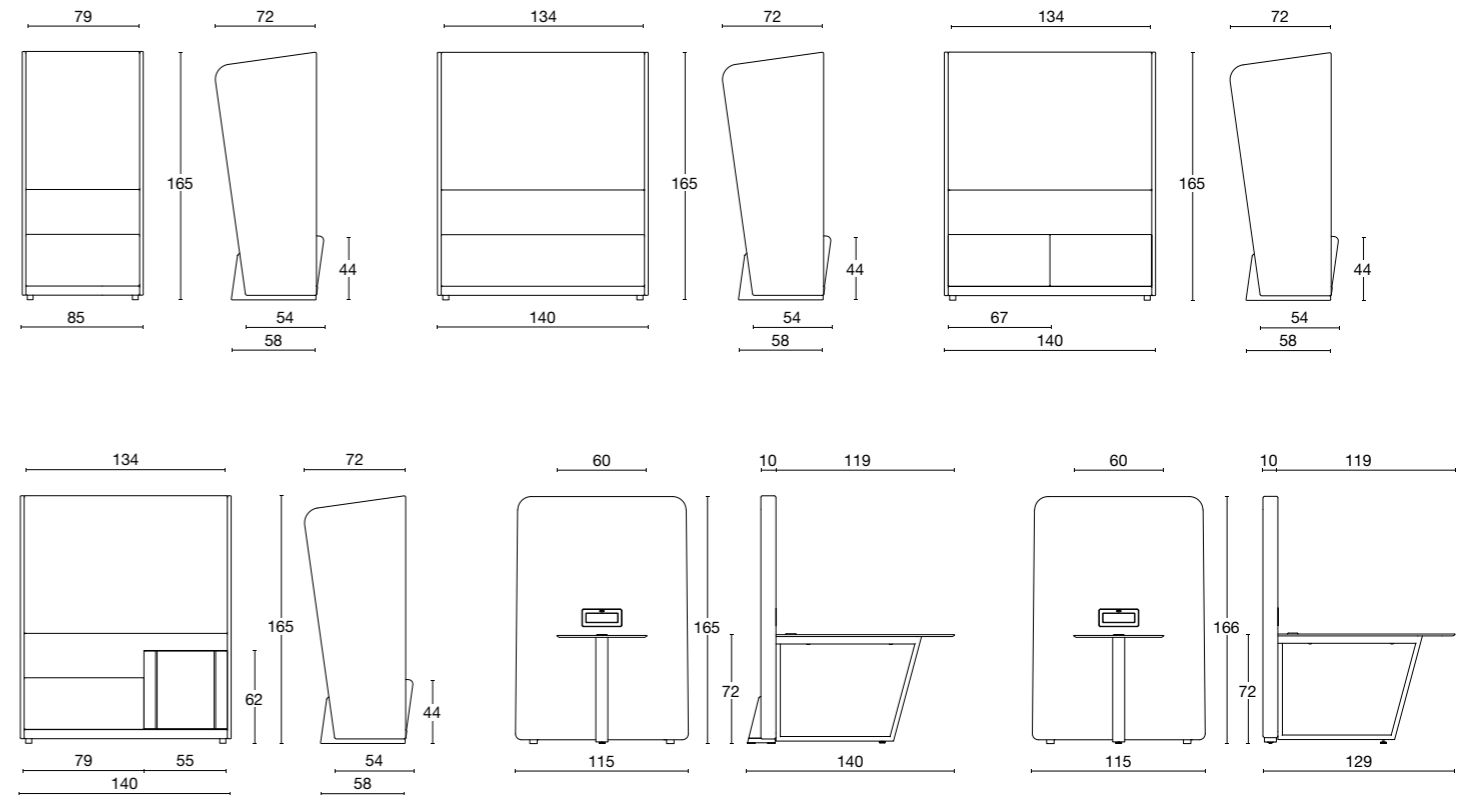

Divano a due posti e poltrona con schienale alto, dalle linee moderne, adatte ad una soluzione che richiede privacy. Interni in legno e imbottitura in poliuretano espanso. Piedini in rovere naturale. Il pannello Circuit Media è dotato di tavolo in hpl con gamba per passaggio cavi, 2 prese USB, predisposto per fissaggio tv e accessoriabile con prese. Fisso o con ruote a scomparsa per spostarlo facilmente.

Two-seater sofa and armchair with high back, with modern lines, suitable as a solution when privacy is required. Wood and polyurethane foam interior. Natural oak feet. The Circuit Media panel is equipped with an HPL table with cable passage leg, 2 USB sockets, ready for TV fixing, and can be fitted with power sockets. Fixed, or with retractable wheels for ease of manoeuvrability.

Canapé deux places et fauteuil avec dossier haut, aux lignes modernes, adapté à une solution qui nécessite de l'intimité. Intérieur en bois et rembourrage mousse de polyuréthane. Pieds en chêne naturel. Il est équipé d'une table HPL avec pied de passage de câble, 2 prises USB, préparé pour la fixation du téléviseur et peut être équipé de prises. Fixé ou avec des roulettes pour le déplacer facilement.



struttura
legno



piedi in rovere / ruote



rivestimento
tessuto



pelle
ecopelle

frame

wood

feet: oak / castors

upholstery

fabric

genuine leather
faux leather

structure

bois

pieds en bois de chêne / roulettes

revêtement

tissu

cuir
simili cuir

CIRCUIT ZOOM



CIRCUIT ZOOM



Circuit Zoom soft seating / Jet 8078 - 8017

CIRCUIT ZOOM

Diemme Lab / 2020



Circuit Zoom | Privè soft seating / Jet 8078 - 3090 - 8017

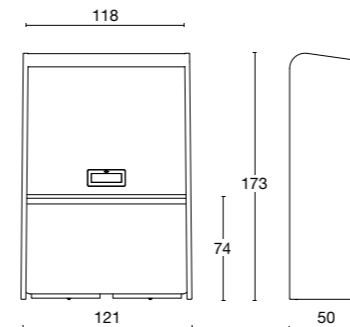

Elemento freestanding, dotato di braccioli, tetto di copertura, piano in melaminico con prese elettriche e predisposizione per lo schermo sulla parete frontale. Adatto come scrivania e soprattutto per videoconferenze nel rispetto della privacy dell'utilizzatore e delle persone circostanti l'ambiente di lavoro, grazie anche all'isolamento acustico. Perfetto da utilizzare sia con una seduta che con il divanetto Circuit Privè per creare una postazione di lavoro confortevole e ancora più intima. Le ruote a scomparsa permettono di spostare facilmente l'elemento secondo le esigenze della stanza e delle persone.

Freestanding cocoon with sides and roof, including a melamine table top with power sockets and panel, to which a monitor can be fitted. Suitable as a workstation and especially for video calls, respecting user privacy and others in the workplace, thanks also to its acoustic absorption properties. Ideal for use with other seating or with the Circuit Privè sofa in order to create an even more comfortable and intimate workplace. Castors allow it to be moved around easily and according to local needs.

Élément autoportant, équipé d'accoudoirs, couverture de toit, plateau en mélaminé avec prises électriques et disposition pour l'écran sur la paroi frontale. Convient comme bureau et surtout pour les visioconférences dans le respect de la vie privée de l'utilisateur et des personnes entourant l'environnement de travail, grâce également à l'isolation acoustique. Parfait à utiliser avec un siège et avec le canapé Circuit Privè pour créer un lieu de travail confortable et encore plus intime. Les roulettes rétractables vous permettent de déplacer facilement l'élément en fonction des besoins de la pièce et des personnes.



struttura
legno



piedini polipropilene / ruote



rivestimento
tessuto



pelle
ecopelle

frame
wood

polypropylene feet / castors

upholstery
fabric

genuine leather
faux leather

structure
bois

pieds en polypropylène / roulettes

revêtement
tissu

cuir
simili cuir

Leggero e contemporaneo, **SNAKE** è un sistema modulare completo. Il suo design è definito dall'armonioso accostamento di linee essenziali a morbide forme curvilinee. La combinazione dei suoi elementi consente molteplici configurazioni, per adattarsi a ogni spazio. L'ampia gamma di moduli ed accessori, trova facilmente spazio in ambienti molto diversi tra loro: dal residenziale al ristorante; dalle zone di attesa all'ufficio.

SNAKE

Diemme Lab / 2020

137

SNAKE

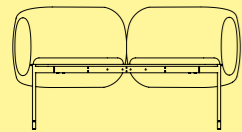

Light and contemporary, SNAKE is a complete modular system. Its design features a smooth blend of clean lines and soft curves. The various pieces can be combined into numerous configurations suited to all kinds of spaces. The wide range of modules and accessories easily slot into very different settings: from residential to restaurant; from waiting areas to offices.

Léger et contemporain, SNAKE est un système modulaire complet. Son design est défini par la combinaison harmonieuse de lignes essentielles avec des formes curvilignes douces. Ses éléments permet de multiples configurations, pour s'adapter à toutes les situations. La large gamme de modules et d'accessoires trouve facilement de l'espace dans des environnements très différents: du résidentiel au restaurant; des zones d'attente au bureau.

Modular system

Il sistema modulare SNAKE è personalizzabile e ricco di elementi. A panche imbottite di diverse lunghezze, disponibili anche con braccioli e schienale, si affiancano tavolini, elementi di elettrificazione, e accessori quali portariviste, porta piante e appendiabiti. Completano la collezione Snake delle pareti divisorie da accostare alle sedute come poggiaschiena o da usare singolarmente per creare zone più riservate. I diversi moduli possono essere utilizzati singolarmente, oppure collegati tra di loro in diverse soluzioni, lineari o angolari per rispondere alle esigenze stilistiche e di spazio dell'ambiente.

The SNAKE modular system is customizable and has a great number of units. The upholstered benches come various lengths, optionally with armrests and backrests, and can be provided with small tables, power points, and accessories such as magazine racks, plant stands and coat-stands. Dividing partitions are also available to be fitted to the seats as backrests or to be used individually to create more areas with personal privacy. The different modules can be built upwards or intersected in single, straight or corner solutions to meet the stylistic and space requirements of the environment.

Le système modulaire SNAKE est personnalisable et riche en éléments. Les bancs rembourrés de différentes longueurs, également disponibles avec accoudoirs et dossier, sont flanqués de tables, d'éléments d'électrification et d'accessoires tels que des porte-revues, des porte-plantes et des porte-manteaux. Des cloisons de séparation sont également disponibles pour être placées à côté des sièges comme dossiers ou pour être utilisées individuellement pour créer des zones plus réservées. Les différents modules peuvent être superposés ou recoupés dans des solutions simples, linéaires ou angulaires pour répondre aux exigences stylistiques et d'espace de l'environnement.

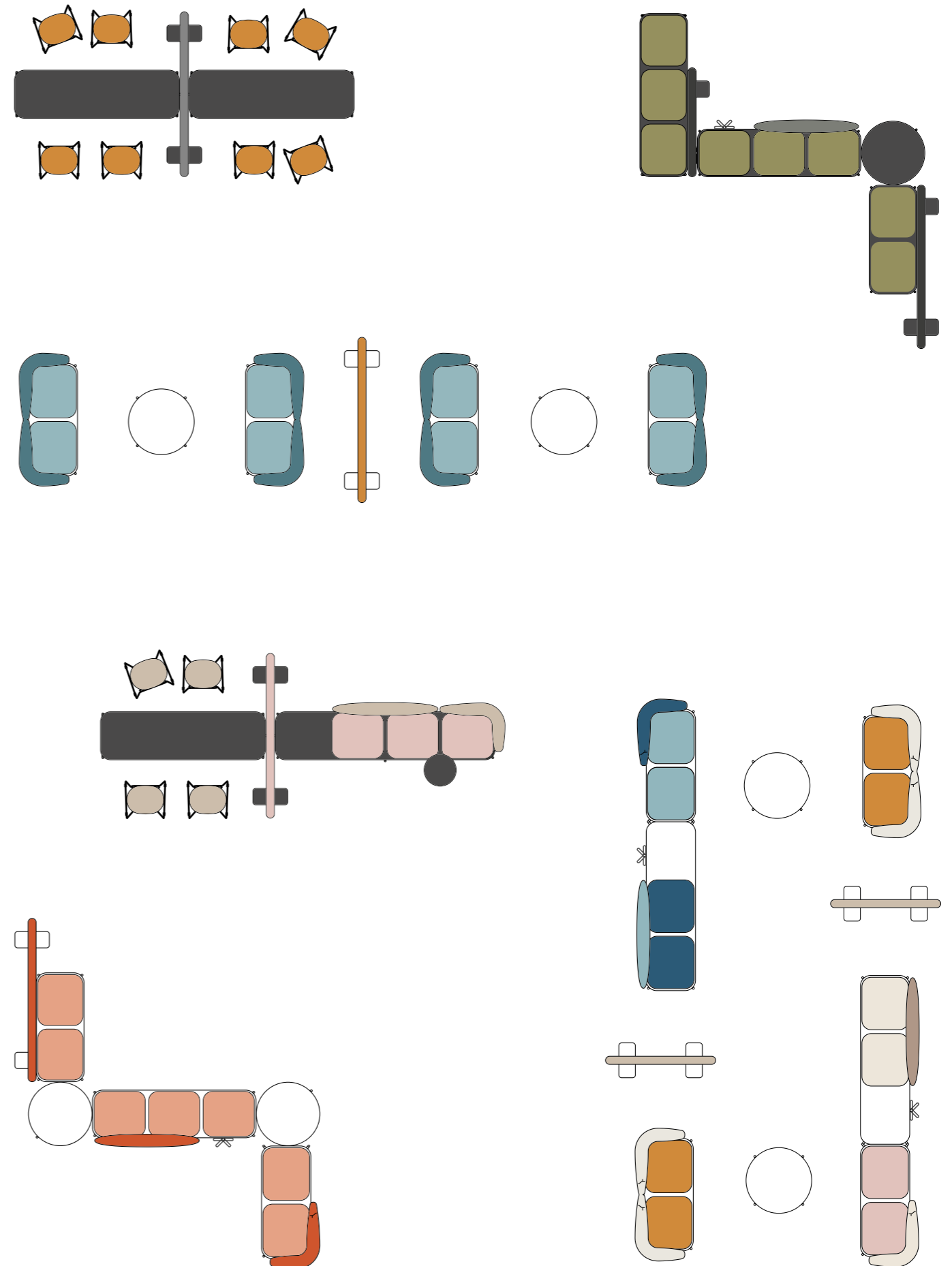

SNAKE



Snake soft seating / Wolin 7050.18 - 7050.39 - 7050.23

SNAKE



Snake soft seating / Wolin 7050.30 - Gorgeous 2155

SNAKE



Snake soft seating / Gorgeous 2131 / Wolin 7050.18 - 7050.27 - 7050.28 / Gorgeous 2112 / Wolin 7050.46

SNAKE



Snake soft seating / Wolin 7050.28



SNAKE

SNAKE

Diemme Lab / 2020

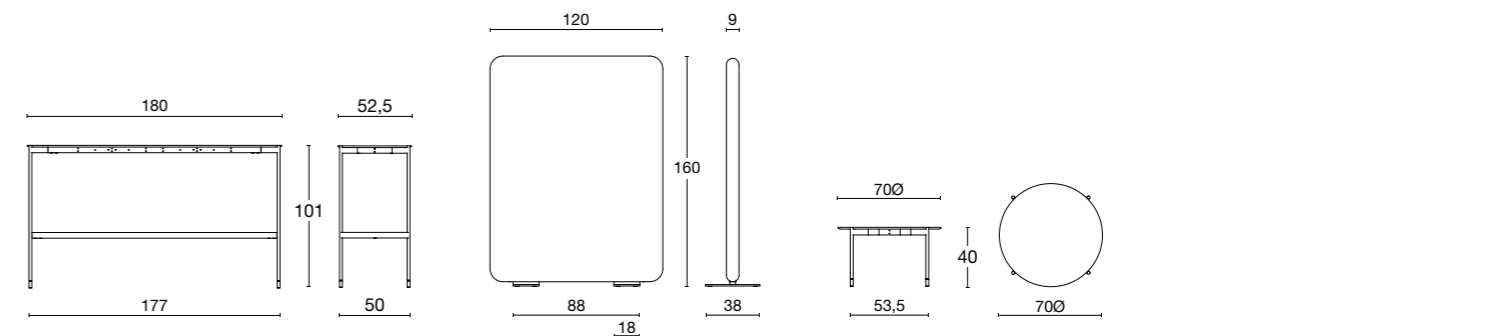
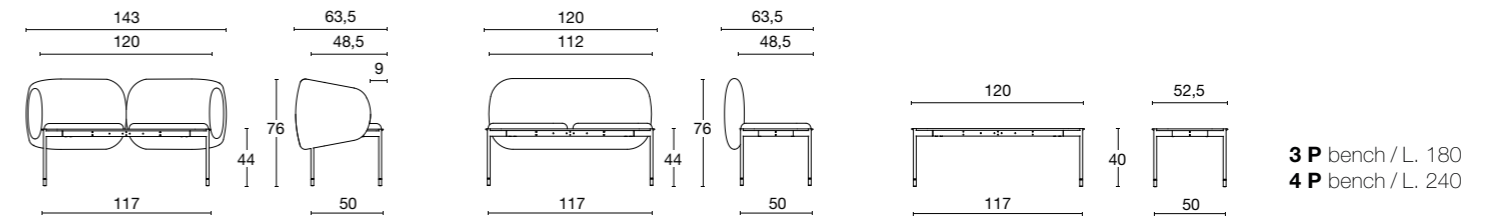

Sistema modulare composto da panche da 2/3/4 posti con seduta in HPL e telaio in metallo verniciato e piedini regolabili. Optional: sedili, schienali e braccioli imbottiti, elementi di elettrificazione, tavolino porta computer, tavolo rotondo adatto anche come angolo per configurazioni a L, e ancora porta abiti e porta oggetti di design conferiscono loro colore e comfort. Pareti divisorie rivestite in 3 misure differenti, utilizzabili indipendenti o fissate alla struttura per dividere gli spazi. Panca h 70 cm adatta come piano d'appoggio o come seduta informale. Tavolo h 101.

A modular system consisting of 2/3 or 4 seater benches with HPL seat, and lacquered metal frame, with adjustable feet. They can be upgraded with accessories as upholstered seats, backs and arms, power points, computer accessory table, round table also suitable as a corner for L-shaped configurations, and even coat-stands, racks and suspended feature shelving. The family also includes three different sizes of upholstered screen. A 70 cm high version of the bench is also available, there is also a 101 cm high table version.

Système modulaire composé de bancs 2/3/4 places avec assise HPL et structure en métal peint, avec pieds réglables. Optional: assises tapissées, dossiers et accoudoirs, éléments d'électrification, une table d'accessoires pour ordinateur, une table ronde également adaptée comme coin pour des configurations en forme de L, et même des porte-manteaux. La famille comprend également des cloisons revêtues (en 3 tailles différentes). La version de 70 cm de haut du banc est également disponible comme surface d'appui ou comme siège informel, et enfin la version table de 101 cm de hauteur.

-  **struttura**
piano: HPL bianco / nero
-  telaio: metallo verniciato bianco / nero
-  **rivestimento**
tessuto
-  pelle
ecopelle

- frame**
top Hpl black / white
- base metal: black / white
- upholstery**
fabric
- genuine leather
faux leather

- structure**
plateau: Hpl blanc / noir
- base en metal: blanc / noir
- revêtement**
tissu
- cuir
simili cuir

“Semplici, moderni e di design,
i complementi d’arredo Diemme
conferiscono carattere agli ambienti
con giochi di contrasto, oppure
con accostamenti tono su tono.
Perfetti per arredare zone lounge,
luoghi di condivisione
e spazi di attesa contemporanei.”

Complementi

Accessories | Accessoires



BREAD

155



CIRCUIT

163

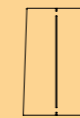

CLOCK

169



XL XS

175

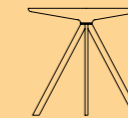

MARGARITA

181



ROCKET

187

“With simple modern design, Diemme’s furnishing accessories, featuring contrasting colours or a two-tone look, add a touch of style to any setting. Ideal for lounges, community and contemporary waiting areas.”

“Simple, moderne et design, accessoires d’ameublement Diemme, avec des jeux de contraste, ou avec des combinaisons ton sur ton, ils donnent du caractère aux chambres. Parfait pour décorer les salons, et les espaces d’attente contemporains.”

BREAD è un sistema di tavoli progettato per essere un complemento utile e facilmente accostabile a diversi stili di design, sia in casa sia nel contract. Tavolini dal gusto tradizionale, con un occhio alla modernità. Il piedino in legno e il piano laccato sono spunti dal retaggio classico rivisti in una chiave più attuale.

BREAD

DorigoDesign / 2015

159

BREAD

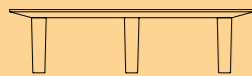

BREAD is a system of minimalist tables. Designed to be a handy range easy to slot into all kinds of residential and contract projects, regardless of their design. Coffee tables of traditional style, with an eye on the modern look, the wooden legs combine with lacquered tops to constitute a contemporary link back to a classical heritage.

BREAD est un système de tables indispensables. Conçu pour être utile mais facilement complémentaire peut-être combiné avec différents styles de conception, à la maison et dans le contract. Tables de goût traditionnelles, avec l'œil à la modernité, le pied en bois juxtaposé au plateau laqué avec un héritage classique revu en une seule touche plus actuel.

BREAD



Bread coffee table / Antracite

BREAD



BREAD

DorigoDesign/ 2015

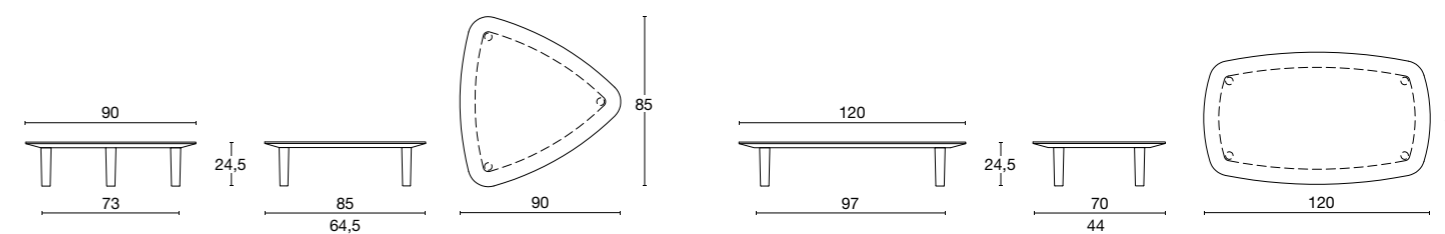
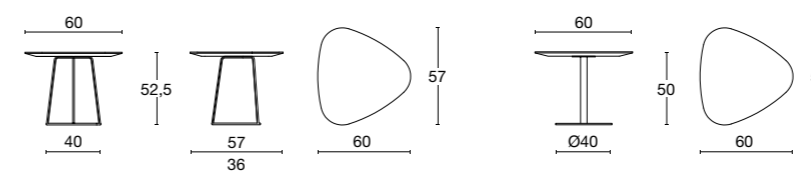

Tavolo da attesa, disponibile in 4 varianti: top rettangolare in MDF colore bianco, antracite o rovere su piedi in rovere naturale o verniciati bianchi h. 23 cm; top triangolare grande in MDF bianco o antracite su piedini in rovere naturale o verniciati bianchi h. 23 cm; top triangolare piccolo in MDF bianco o antracite su basamento cromato tondo h. 50 cm o ancora su basamento verniciato bianco h. 50 cm.

Waiting table, available in 4 variants: oblong MDF top in white, dark grey or natural oak finish, on natural or white lacquered oak feet h. 23 cm; large white or dark grey triangular top on natural or white lacquered oak feet h. 23 cm; small triangular white or dark grey MDF top on round chromed h. 50. cm base; alternatively on white lacquered base h. 50 cm.

Table d'attente, disponible en 4 variantes: plateau rectangulaire en MDF couleur blanc ou anthracite sur pieds en chêne naturel ou peint en blanc h 23 cm; grand plateau triangulaire en MDF blanc ou anthracite sur pieds métalliques chêne naturel ou peint en blanc h 23 cm; petit haut triangulaire en mdf blanc ou anthracite sur piètement rond chromé h 50 cm ou peint en blanc h 50 cm.

struttura
base cromata / verniciata bianca / piedini in legno di rovere naturale / verniciati bianchi

top
MDF antracite / bianco / rovere naturale

frame
base: chromed metal / white lacquered / feet in natural oak / white lacquered

top
MDF anthracite / white / natural oak

structure
base en metal chromé / peint blanc / pieds en chêne / peint blanc

plateau
MDF anthracite / blanc / chêne

Il tavolino **CIRCUIT** completa
la collezione di sedute modulari
dalle composizioni originali
e adatte a ogni tipo di spazio.
Elegante, dalla linea esile
e slanciata, è un complemento ideale
per molteplici esigenze di arredo.

CIRCUIT

DorigoDesign / 2013

163

CIRCUIT

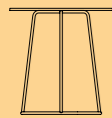

The low CIRCUIT table complements a highly original and versatile modular seating unit, suited to every type of setting. Elegantly slender and angled, this is an ideal addition to all manner of furnishing scenarios.

La table basse CIRCUIT complète une collection de sièges modulaire avec des compositions originales et polyvalentes adaptées à tout type d'espace. Élegante, avec une ligne mince, c'est un complément idéal pour beaucoup de besoins d'ameublement.

CIRCUIT

DorigoDesign / 2013



Circuit coffee table / Nero

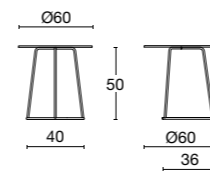

Tavolo con telaio verniciato bianco o nero e piano in hpl bianco o nero, adatto a diverse tipologie di ambienti.

Table with black or white lacquered frame and top in hpl, suited to all kinds of settings.

Table avec structure peinte en blanc ou noir et plateau en hpl blanc ou noir, elle s'adapte à différents types d'environnements.



struttura
base metallo bianco / nero

frame
base metal: white / black

structure
base en métal blanc / noir



top
hpl

top
hpl

plateau
hpl

CLOCK fa della semplicità e della razionalità i suoi principali valori. Complemento semplice ma molto funzionale, è in grado di conferire una forte caratterizzazione allo spazio. Utile come work table, se accostato a divani o poltrone crea un comodo angolo smart working anche negli spazi ridotti.

CLOCK

DorigoDesign / 2015

169

CLOCK



CLOCK oozes simplicity and rationality. A simple but extremely useful accessory which can become a striking interior design feature. Clock can perform as a worktop in conjunction with sofas or armchairs, creating a comfy smart working corner even in tight spaces.

CLOCK, la simplicité et la rationalité sont ses principales valeurs. Un complément simple mais très fonctionnel, peut assurer une forte caractérisation de l'espace. Utile comme table de travail si à côté de canapés ou fauteuils, crée un angle de travail intelligent et confortable même dans les plus petits espaces.

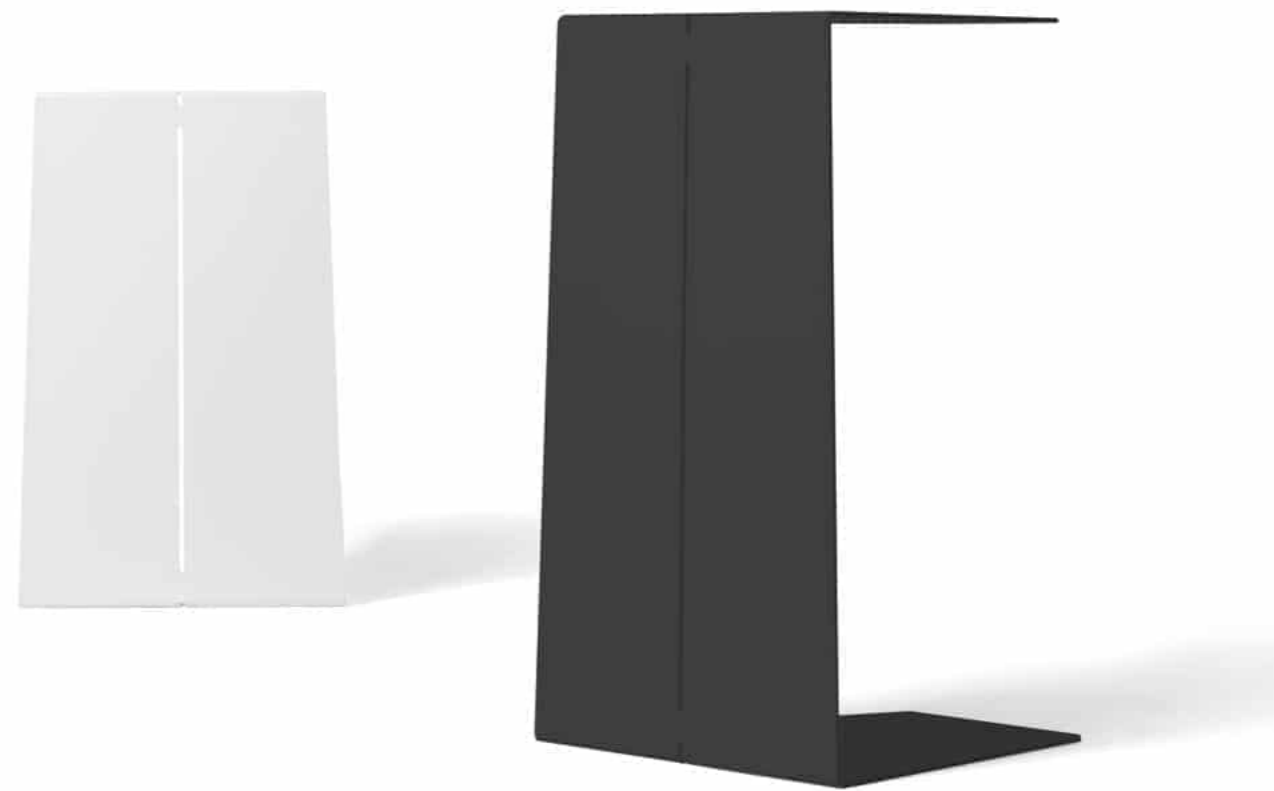

CLOCK



CLOCK

DorigoDesign / 2015

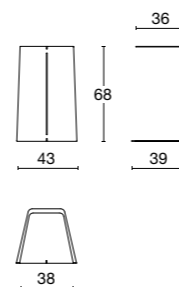

Tavolino in acciaio verniciato bianco o antracite, ideale per arredare ambienti office e contract. Funzionale anche come porta laptop, per una postazione di lavoro informale, o come piano d'appoggio multifunzionale.

Steel coffee table lacquered white or dark grey, ideal for office and contract applications. It also works as a lap-top table for informal working, or as a general multi-purpose top.

Table basse en acier peint blanc ou anthracite, idéale pour l'ameublement de bureaux et de collectivités. Également fonctionnel comme support d'ordinateur portable, pour un lieu de travail informel ou comme plateau de table multifonctionnel.



struttura

acciaio verniciato antracite / bianco

frame

white / dark grey lacquered steel

structure

acier peint anthracite / blanc

XL e **XS** sono superfici semplici ed essenziali che poggiano su una lama di metallo per un'estetica pura. Il caratteristico incrocio del basamento ne determina l'ispirazione per il nome e dona loro un design unico. I tavolini sono riconoscibili per la dimensione: piccola nella versione XS e più grande nella versione XL.

XL XS

Plus Design / 2008

175

XL XS

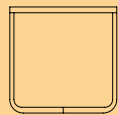

A simple and minimalist item resting on a metal blade for a highly stylized look. The cross-base inspires the name and creates unique design, with recognisable dimensions, low in the XS version and high in XL.

Un objet simple et indispensable reposant sur une lame métallique pour une esthétique pure. La croix caractéristique de la base détermine l'inspiration du nom, donne un design unique et reconnaissable à sa taille, petit dans la version XS et plus grand dans la version XL.

XL XS

Plus Design / 2008



XL coffee table / Nero

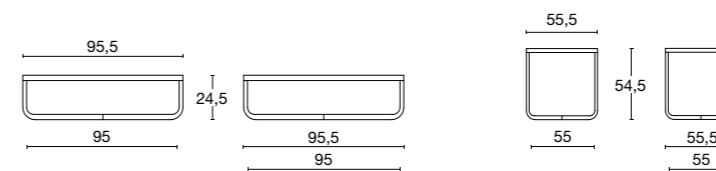

Tavolo da attesa, con struttura in tubo metallico verniciato, ripiano in HPL bianco o nero disponibile in due altezze diverse.

Waiting table with lacquered metal tube frame, black or white compact laminate top.

Table d'attente, avec structure en tube de métal peint, plateau en HPL blanc ou noir.



struttura
base metallo bianco / nero

frame
base metal: white / black

structure
base en métal blanc / noir



top
hpl

top
hpl

plateau
hpl

Caratterizzati da una silhouette
semplice e moderna,
i tavoli **MARGARITA** si adattano
ai contesti più diversi:
dagli ambienti commerciali
alle aree lounge,
dagli spazi indoor a quelli outdoor.

MARGARITA

DorigoDesign / 2016

181

MARGARITA

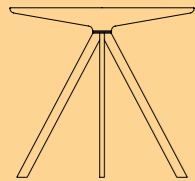

With their distinctively modern fine lines, MARGARITA tables fit handily into all kinds of settings, whether commercial, or lounges, indoors or even out.

Caractérisées par une silhouette simple et moderne, les tables MARGARITA s'adaptent aux contextes les plus divers, des environnements commerciaux aux salons, des espaces intérieurs à ceux qui sont dehors.

MARGARITA

DorigoDesign / 2016



Margarita snack table / Antracite

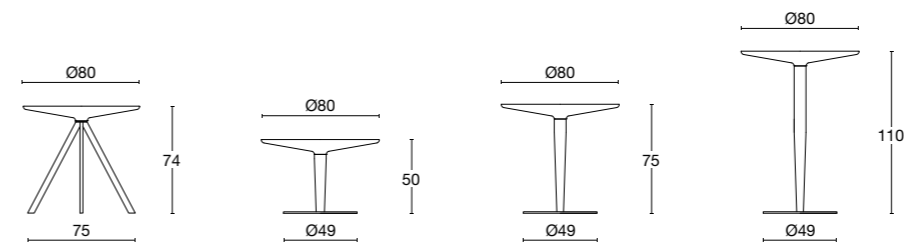

Tavoli, con top rotondo di diametro 80 cm in polietilene bianco o antracite, basamenti in metallo verniciato bianco o antracite a 4 gambe altezza 74 cm oppure centrale, in 3 diverse altezze: 50 cm, 75 cm e 110 cm. Adatto anche all'esterno.

Tops with white or dark grey Ø80 cm polyethylene tops with matching lacquered 4-legged metal bases h. 74 cm, or central base in choice of three heights: 50 cm, 75 cm or 110 cm. Suitable also for outdoor use.

Tables avec plateau polyéthylène rond de 80 cm de diamètre en blanc ou anthracite, piètement en métal peint blanc ou anthracite à 4 pieds hauteur 74 cm ou centrale, en 3 hauteurs différentes: 50 cm, 75 cm et 110 cm. Convient également à l'extérieur.



struttura

base metallo antracite / bianco



top

top polietilene antracite / bianco

frame

metal frame: dark grey / white

top

polyethylene top: dark grey / white

structure

base en métal anthracite / blanc

plateau

polyéthylène anthracite / blanc

Gli appendiabiti **ROCKET**, ideali per l'ufficio e per gli spazi collettivi, decorano ambienti e pareti donando modernità e vivacità.

ROCKET

Diemme Lab / 2017

187

ROCKET

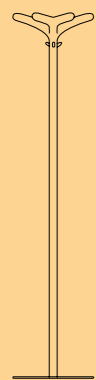

ROCKET coat-stands brighten up any area or wall, bringing life and modernity, ideal for offices and commercial applications.

Le porte-manteau ROCKET décore les espaces et les murs, donnant modernité et vivacité, idéal pour le bureau et pour les espaces collectifs.

ROCKET

Diemme Lab / 2017

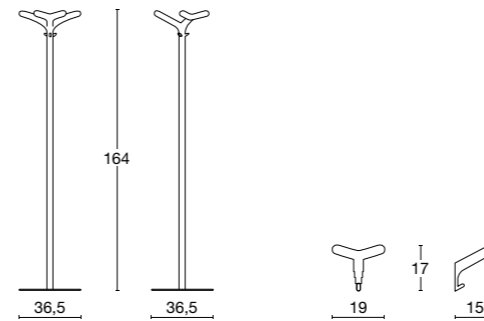

Serie di appendiabiti con struttura in metallo verniciato a polveri epossidiche, ideale per la collettività in generale. L'appendiabiti da parete consente, in uno spazio ridottissimo, di appendere almeno tre capi; la versione da terra ha basamento tondo centrale con portaombrelli ed è strutturato con nove ganci.

A collection of coat-stands with epoxy coated metal frames, ideal for any contract setting. The wall hooks allow up to three coats to be hung in any enclosed space, while the free-standing version has a round column with umbrella ring and nine hooks.

Série de porte-manteau avec structure en métal enduit de poudre époxy, idéal pour le grand public. Le porte-manteau mural permet, dans un très petit espace, d'accrocher au moins trois manteaux; la version au sol a une base ronde centrale avec porte-parapluie et est structuré avec neuf patères.

Rocket wall hanger / Rosso / Nero / Bianco



struttura
acciaio e polipropilene



bianco / nero / rosso

frame

steel and polypropylene

white / red / black

structure

acier et polypropylène

blanc / noir / rouge

Rivestimenti
Upholstery | Nuanciers

JET / CAT. F

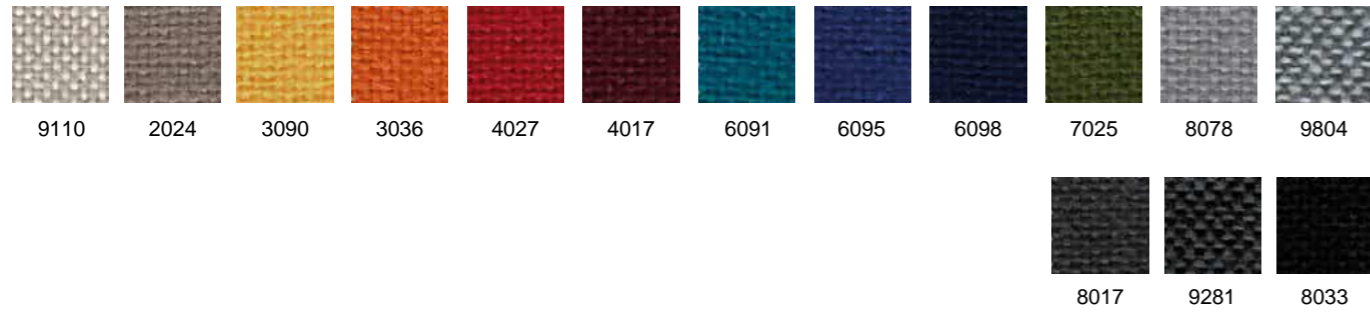

ERA / CAT. S



PLANET - SURROUND / CAT. F



IKON / CAT. TOP

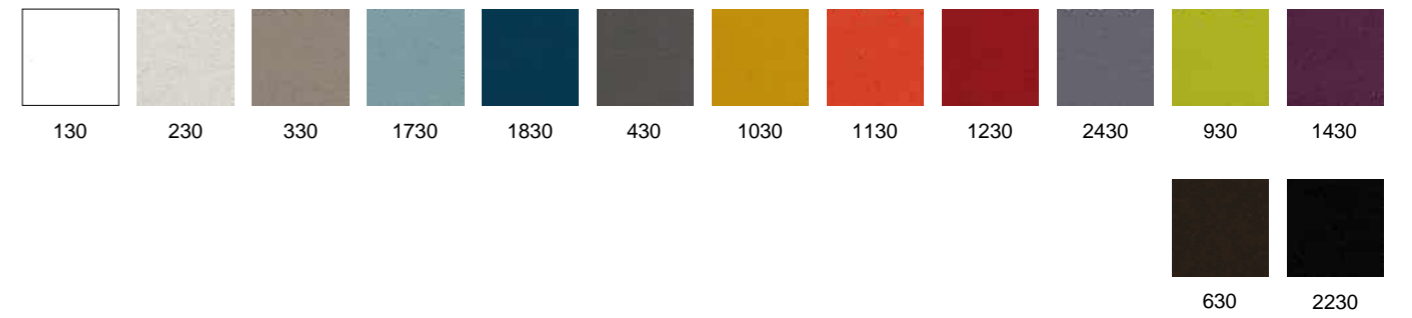

BINGO ELAST - MIRAGE / CAT. G

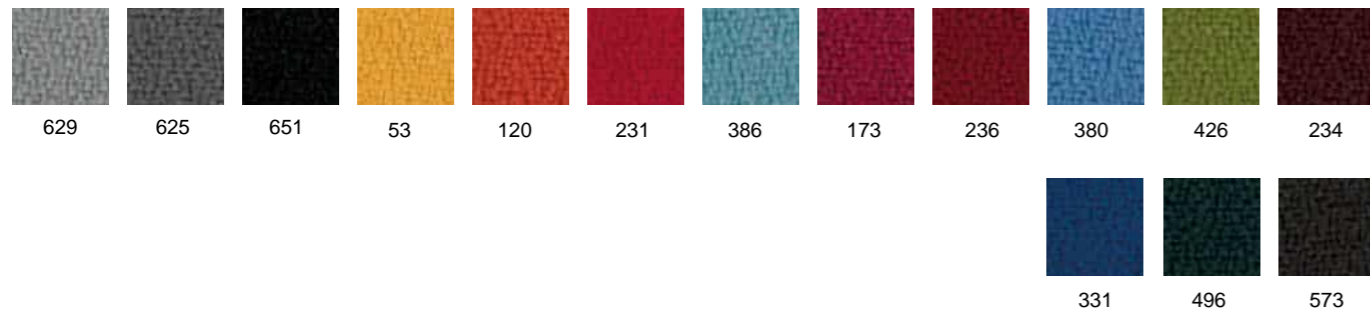

BLAZER / CAT. EXTRA



CUBE / CAT. G

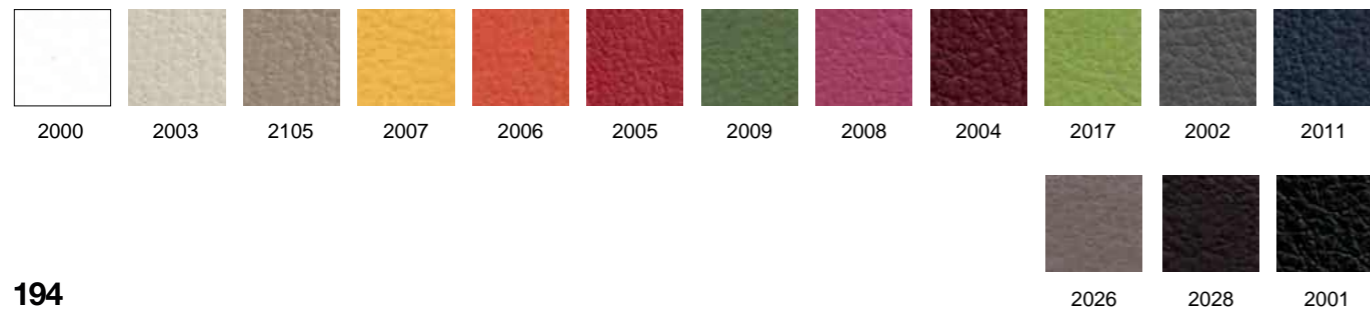

GORGEOUS / CAT. EXTRA

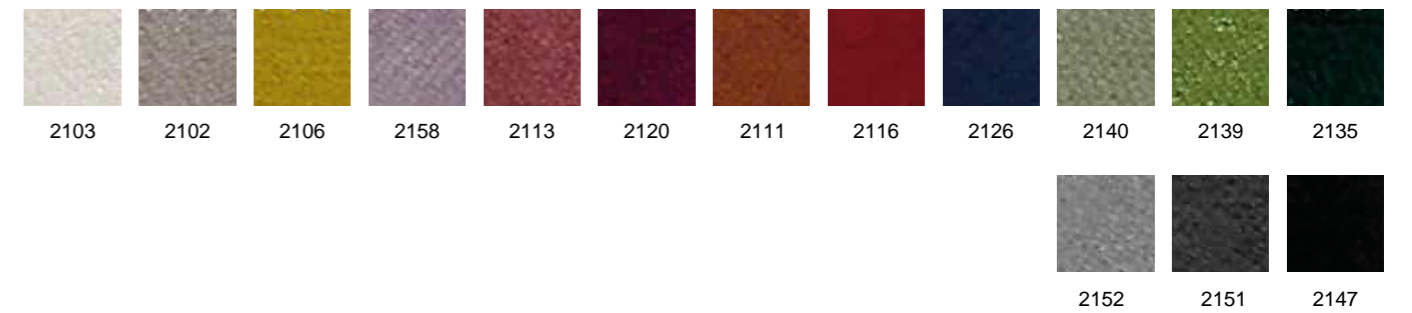

HESTAN / CAT. EXTRA

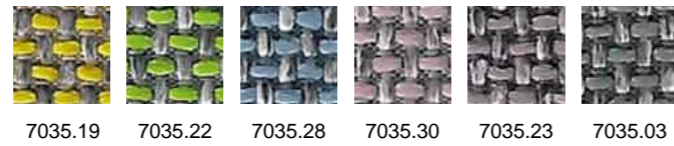

WOLIN / CAT. EXTRA



POLO / CAT. FIESTA

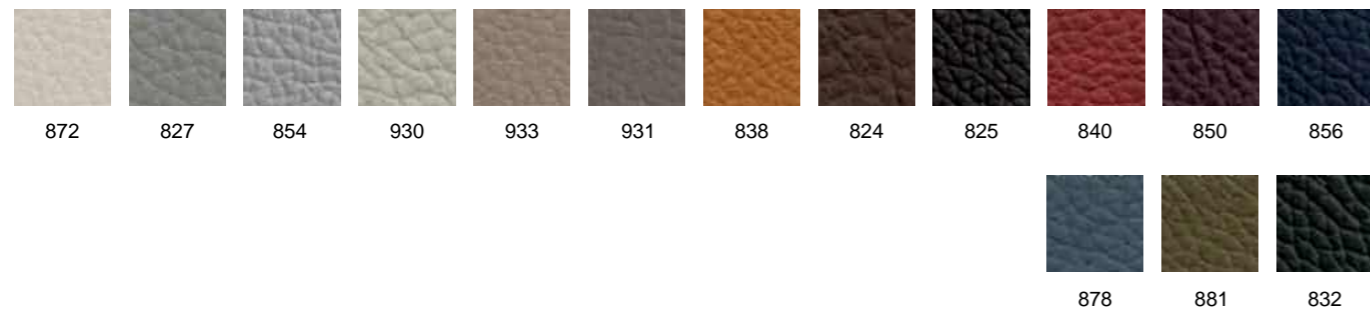

FIESTA



NUVOLA

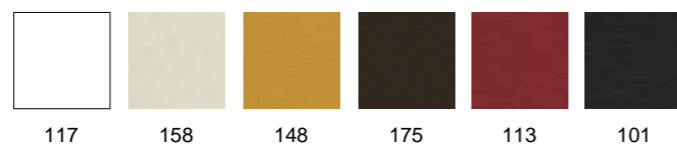

SEDIA IN CUOIO | Hide | Cuir sellier / CLOP



RETI | Mesh | Résille / AUCKLAND

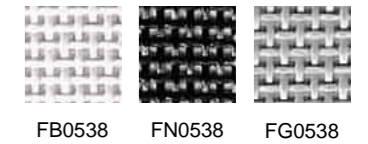

RETI | Mesh | Résille / GOAL / HOP / LEAD / NEW BONN / SOCIAL

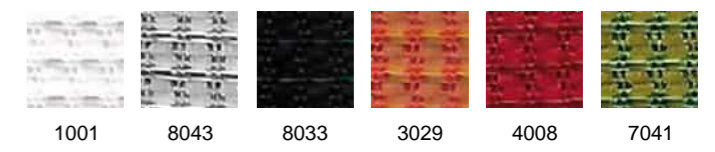

RETI | Mesh | Résille / LIBERTY

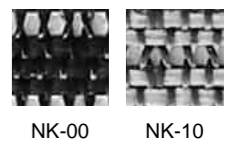

RETI | Mesh | Résille / FIT / SOCIAL



POLIPROPILENE | Polypropylene | Polypropylène / NEW BONN

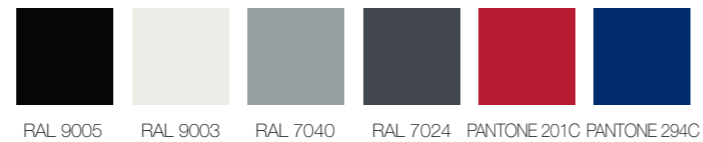

POLIPROPILENE | Polypropylene | Polypropylène / NO FRILL

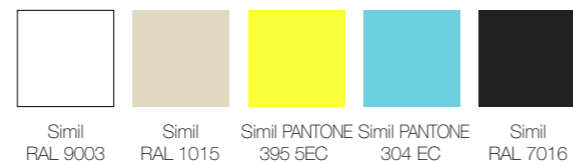

POLIPROPILENE | Polypropylene | Polypropylène / NUKE



POLIPROPILENE | Polypropylene | Polypropylène / REDHOT



POLIPROPILENE | Polypropylene | Polypropylène / SLIM

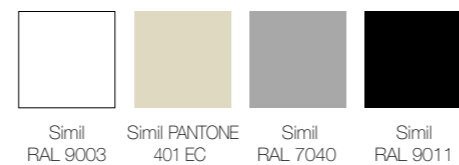

POLIPROPILENE | Polypropylene | Polypropylène / SUNNY NEW

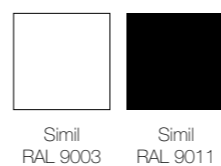

POLIPROPILENE | Polypropylene | Polypropylène / CLOP



POLIURETANO RIGIDO TECH | Tech polyurethane | Tech polyuréthane / EON

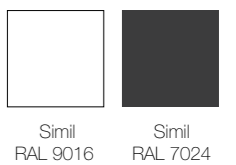

COLORI BICOLOR | Two-colors shell | Coque bicolore / EON

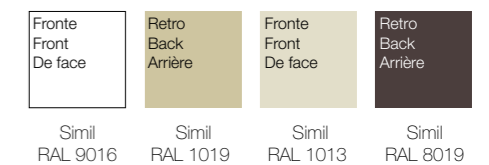

POLIETILENE SEDIA | Polyethylene chair | Polyéthylène chaise / MARGARITA



POLIETILENE TAVOLO | Polyethylene table | Polyéthylène table / MARGARITA

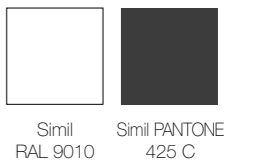



Distributor pro ČR a SK
www.mintiga.cz
obchod@mintiga.cz
+420 724 124 042

Art direction: Priority Design

Graphic design concept: Priority Design

Photo: Arch. Prior Vinicio

Styling: Baliviera Enrica

Post production: Priority Design

Printed by: Graficart Arti Grafiche

Thanks to: Artemide | Axia | Brionvega | Campana Moquette | Cini&Nils | Joe Colombo | Seletti | Venini

09/2020

Diemme Srl

Via del Lavoro, 25 | 31013 Codognè TV | Italy

T. +39 0438 778211

F. +39 0438 479836

dm@diemmeoffice.com

www.diemmeoffice.com

Diemme.